







SPECTRUM

WELDING SUPPLIES

HIRE • SALES • REPAIR • REFURBISH



SPECTRUM 20 TONNE CONVENTIONAL ROTATOR SET

 20 TONNE CAPACITY  380-480V  350mm  5000mm

T 01246 205 267 E info@spectrumweldingsupplies.co.uk W spectrumweldingsupplies.co.uk



SPECTRUM 20 TONNE CONVENTIONAL ROTATOR SET

DRIVE
& IDLER

Model	Conventional Rotator Set (<i>Drive and Idler</i>)
Safe Working Load - Drive Unit	10 tonne
Safe Working Load - Idler Unit	10 tonne
Maximum Load Carrying Capacity - Set	20 tonne (1 Drive & 1 Idler)
Rotation Capacity, Drive Unit	30 tonne
Wheel Centre Distance	18.9, 30.7, 42.5, 66.1, 89.8in (480, 780, 1080, 1680, 2280mm)
Vessel Diameter Capacity	13.8in to 196.9in (350mm to /5000mm)
Rotation Speed Range	5.5 to 55.1 in/min (140 to 1400mm/min)
Tyre Type	Polyurethane, 95A durometer shore rating
Wheel Size	15in diameter x 5in wide (381mm x 127mm)
Overall Height to Top of Tyre	24.6in (625mm)
Remote Pendant Type	Plug & Socket Five Push Button Control (forward/stop/reverse/speed control/e-stop), 50ft (15m) cable
Rotation Drive Motors	2 x 0.75kW
Primary Input Power	380 to 480 V, 3 Phase, 50/60Hz
Input Current at Rated Load	6.8amp
Overall Length & Width - Drive	112.2in x 24in (2850mm x 610mm)
Overall Length & Width - Idler	112.2in x 16.1in (2850mm x 410mm)
Weight - Drive	1645lb (750kg)
Weight - Idler	1102lb (500kg)

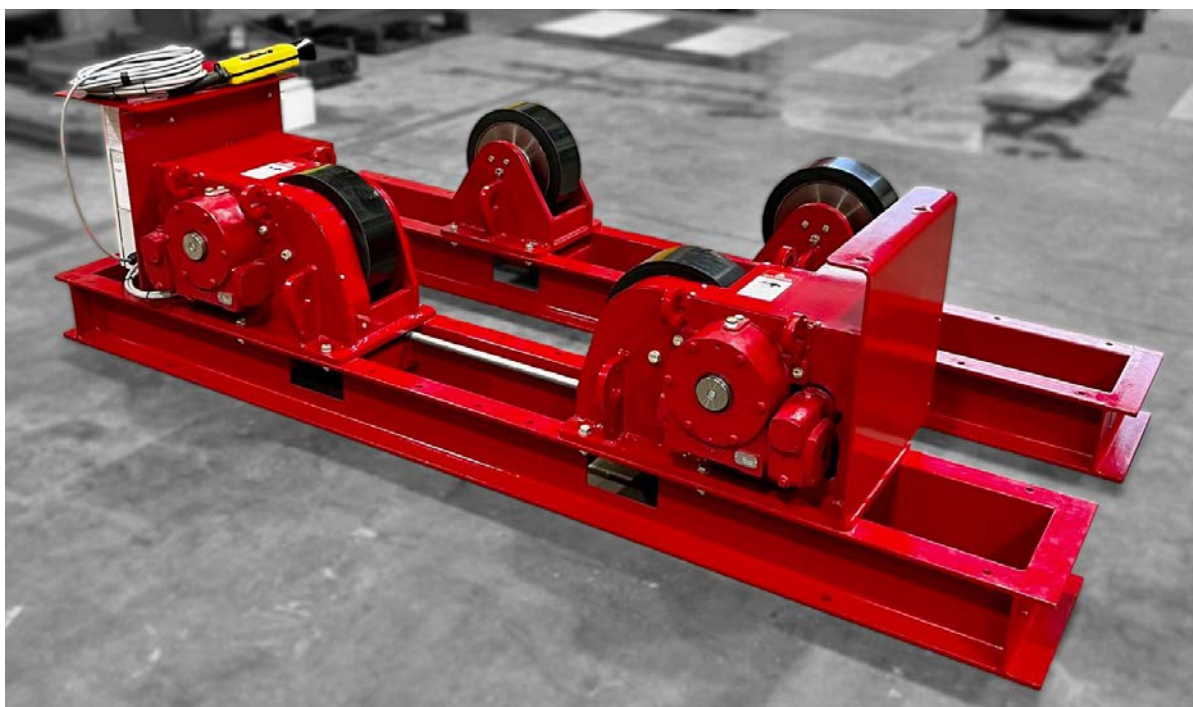



SPECTRUM 20 TONNE CONVENTIONAL ROTATOR SET

DRIVE
 & IDLER

Idler Rotator

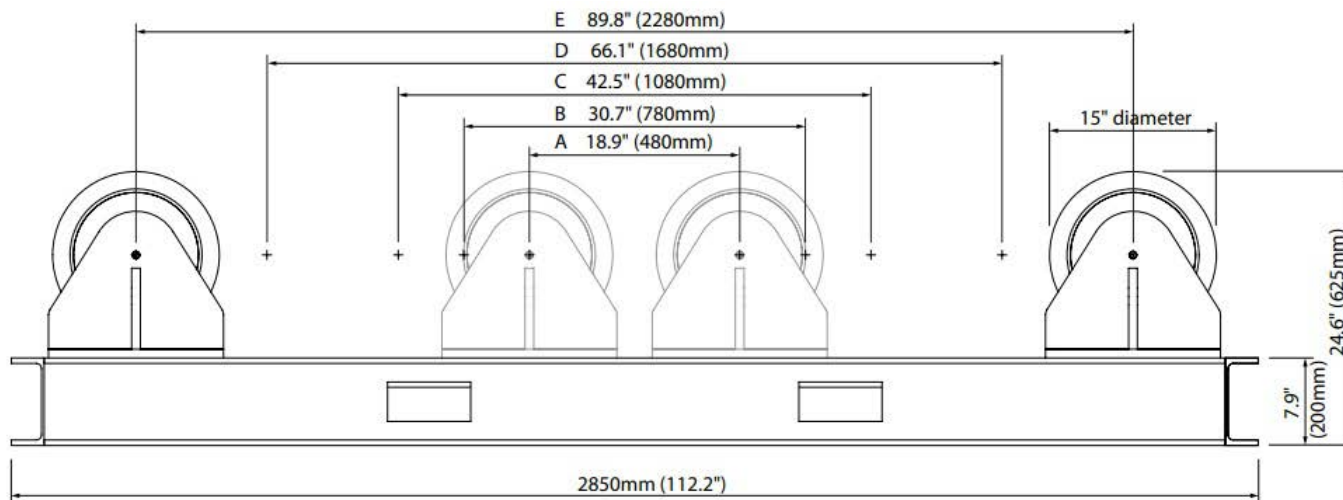
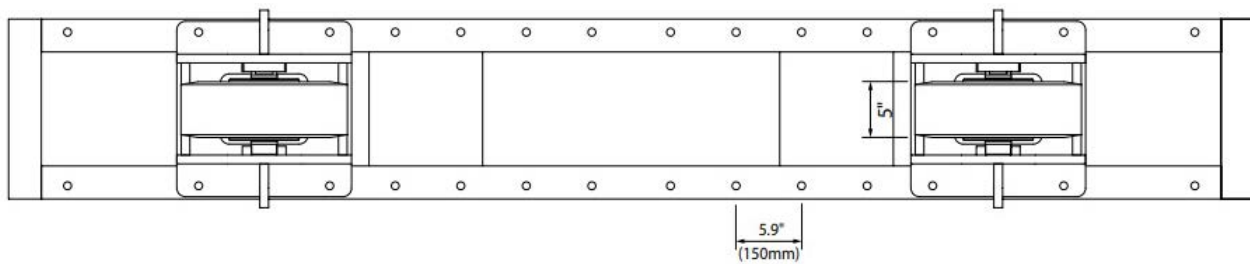

Wheel Setting Workpiece Diameter Range

Setting	Range
A	13.8" (350mm) - 31.5" (800mm)
B	31.5" (800mm) - 55.1" (1400mm)
C	51.2" (1300mm) - 86.6" (2200mm)
D	86.6" (2200mm) - 141.7" (3600mm)
E	126" (3200) - 196.9" (5000mm)

Symbols

- Load capacity
- Supply voltage
- Minimum overall diameter (mm)
- Maximum overall diameter (mm)



SPECTRUM
WELDING SUPPLIES

T 01246 205 267
E info@spectrumweldingsupplies.co.uk
W spectrumweldingsupplies.co.uk

SPECTRUM 20 TONNE CONVENTIONAL ROTATOR SET

DRIVE
& IDLER

Drive Rotator

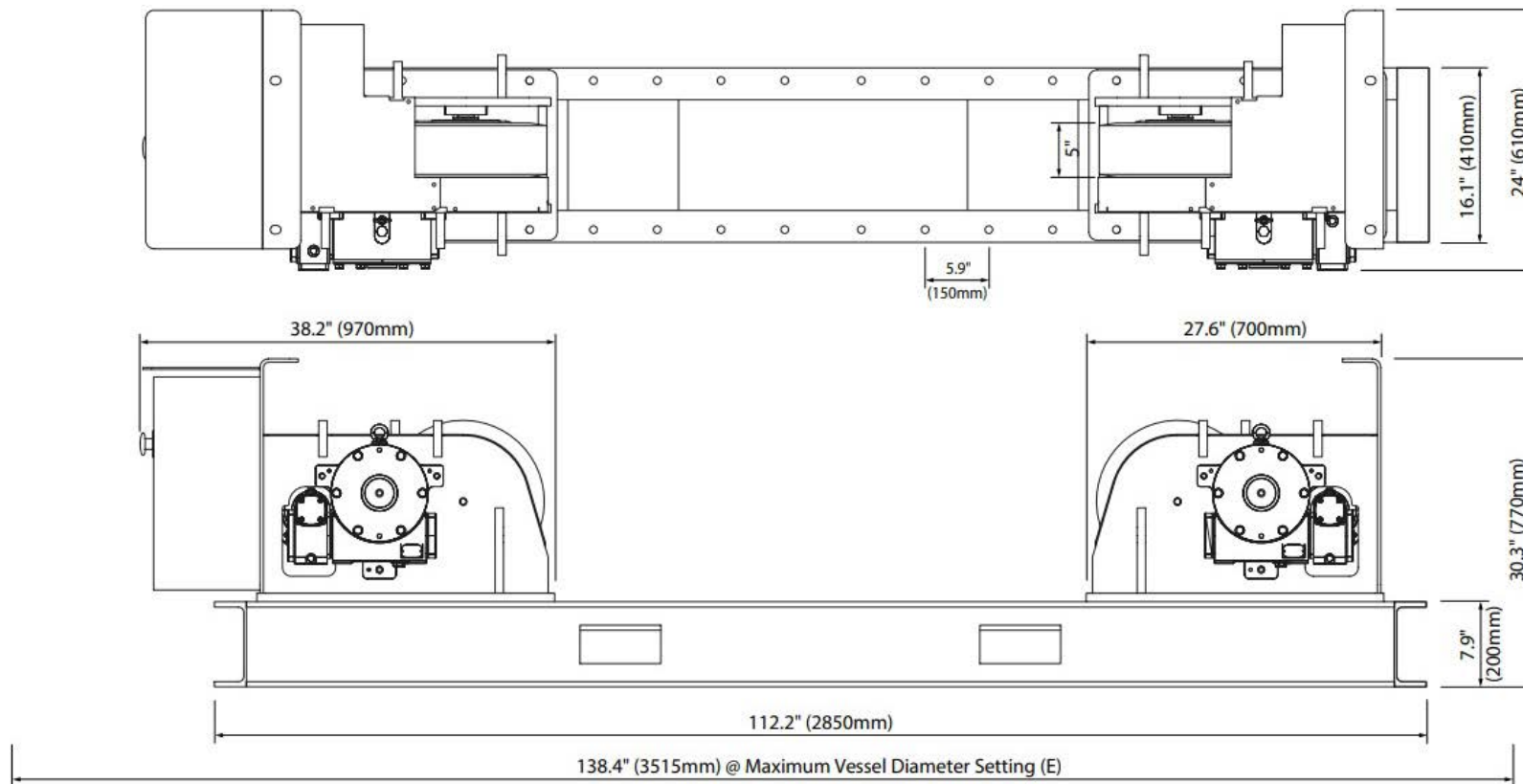



Spectrum Welding Supplies Ltd, Spectrum House,
McGregor's Way, Chesterfield, Derbyshire, S40 2WB

Registered Office: Spectrum House, McGregor's Way,
Chesterfield, Derbyshire, S40 2WB

Registered in England and Wales Company Registration No. 1732286

Vat Registration No. 401 5037 11