

### **TROUBLESHOOTING GUIDE, CONTINUED....**

On some applications it is necessary to move the two (2) Support Rollers (item #2 below) closer to the Main Roller to prevent the machine, or plate, from 'kicking/bucking' at the start and at the end of the bevel, thereby providing a more constant bevel across the whole edge of the plate.

It may also be necessary to move the Support Rollers to the inner holes of the Support Roller Plate when bevelling malleable material, especially thin malleable plate. This will provide support to the plate closer to where the material is being sheared, thus reducing plate deformation and improving the starting feed.

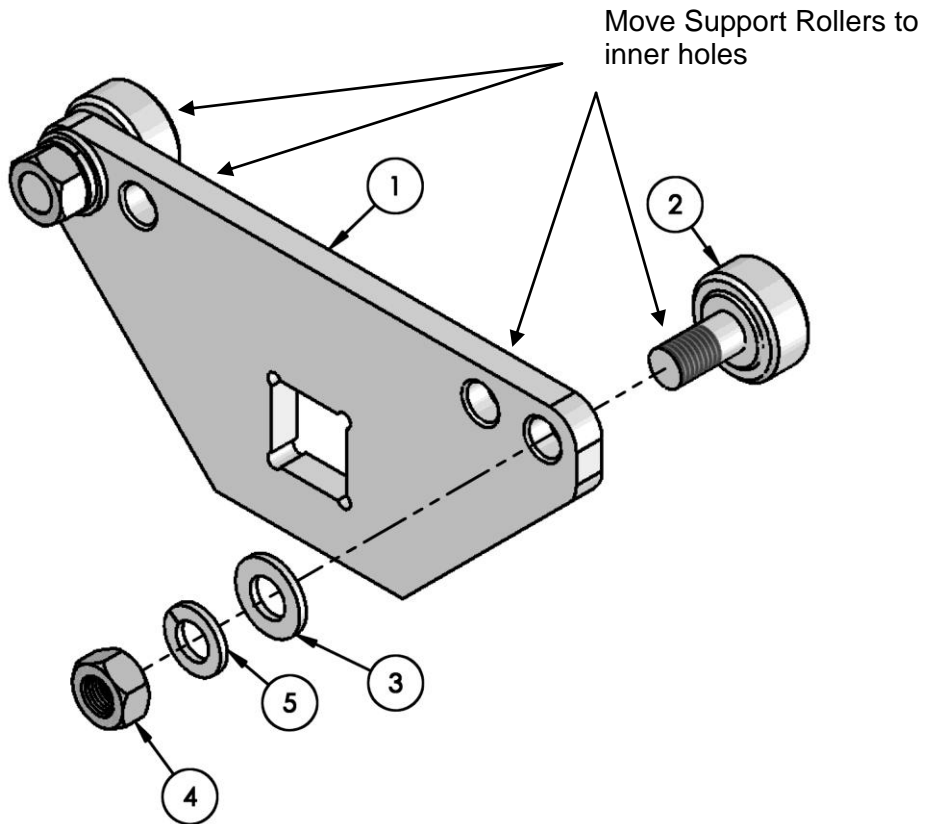

# **KBM®-18-100 GENERAL ASSEMBLY BREAKDOWN**

Drawing Number: KBM-18-100

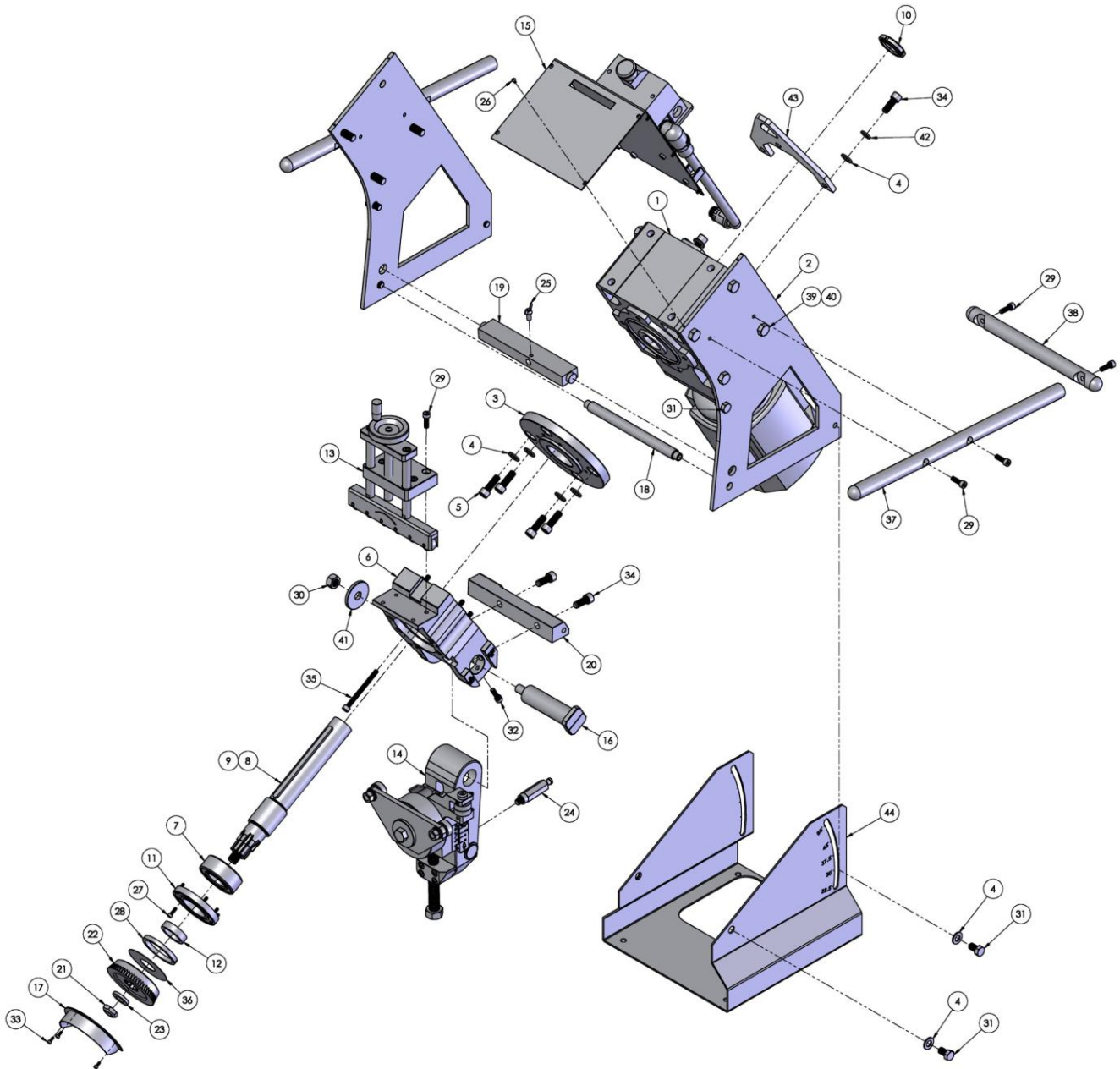

## KBM®-18-100 GENERAL ASSEMBLY BREAKDOWN

Drawing Number: KBM-18-100

ITEM	PART NUMBER	DESCRIPTION	QTY
1	KBM-18-120-A	230/460V GEARMOTOR (KBM-18-100-A, B, C & D)	1
	KBM-18-120-B	575V GEARMOTOR (KBM-18-100-E)	
2	KBM-18-034	BODY SIDE	2
3	KBM-18-098	GEARBOX MOUNT	1
4	GK-111-095	WASHER 12mm BOLT x 24 OD x 2.5	11
5	GK-107-137	M12-1.75 x 35mm SHCS	4
6	KBM-18-035	CUTTER SHAFT HOUSING	1
7	KBM-18-05759	MAIN ROLLER BEARING	1
8	KBM-18-032	CUTTER SHAFT	1
9	KBM-18-033	CUTTER SHAFT KEY	1
10	KBM-18-111	M40-1.5 SELF LOCKING NUT	1
11	GBM-18-031	STOP DISC	1
12	GBM-18-076	CUTTER SHAFT COLLAR	1
13	KBM-18-024	CLAMP ROLLER ASSEMBLY	1
14	KBM-18-025	PIVOT ARM ASSEMBLY	1
15	KBM-18-028	STARTER ASSEMBLY	1
16	KBM-18-030	ANGLE ALIGNMENT BOLT	1
17	KBM-18-036	CUTTER GUARD	1
18	KBM-18-045	TILT BAR	1
19	KBM-18-055	ANGLE SUPPORT BAR	1
20	KBM-18-070	MAIN SUPPORT BAR	1
21	GBM-18-07786	CUTTER NUT	1
22	GBM-18-X1	DEEP TOOTH CUTTER	1
	GBM-18-FXS	SHALLOW TOOTH CUTTER	
	KBM-18-X1C	MEDIUM TOOTH CUTTER	
23	KBM-18-106	CUTTER SHAFT WASHER	1
24	GBM-18-020-225	22.5 DEGREE ANGLE PIN	1
	GBM-18-020-30	30 DEGREE ANGLE PIN	
	GBM-18-020-375	37.5 DEGREE ANGLE PIN	
	GBM-18-020-045	45 DEGREE ANGLE PIN	
	GBM-18-020-055	55 DEGREE ANGLE PIN	
25	GK-161-002	WING SCREW M8-1.25 x 15mm	1
26	GK-112-129	M4-0.7 x 8mm BHCS	10
27	GK-107-140	M5-0.8 x 16mm SHCS	8
28	GBM-18-094	CUTTER FELT INSERT	1
29	GK-107-121	M8-1.25 x 25mm SHCS	10
30	GK-135-061	M16-2.0 NYLOK HEX NUT	1
31	GK-108-144	M12-1.75 x 20mm HEX BOLT	6
32	GK-107-106	M8-1.25 x 30mm SHCS	2
33	GK-107-139	M4-0.7 x 10mm SHCS	3
34	GK-107-144	M12-1.75 x 30mm SHCS	5
35	GK-107-138	M8-1.25 x 90mm SHCS	7
36	GBM-18-015-A	0.5mm CUTTER SHIM (FOR USE WITH GROUND CUTTER)	AS NEEDED
	GBM-18-015-B	1.0mm CUTTER SHIM (FOR USE WITH GROUND CUTTER)	
37	KBM-18-023	HANDLE	2
38	KBM-18-022	HANDLE SUPPORT	1
39	GK-108-151	M14-2.0 x 35mm HEX BOLT	8
40	GK-109-081	M14-2.0 HEX NUT	8
41	KBM-18-031	HEAVY DUTY WASHER	1
42	GK-136-070	LOCK WASHER 12mm BOLT	3
43	KBM-18-076	LIFTING PLATE	1
44	KBM-18-081	TILTING FRAME	1

## CLAMP ROLLER ASSEMBLY BREAKDOWN

Part Number: KBM-18-024

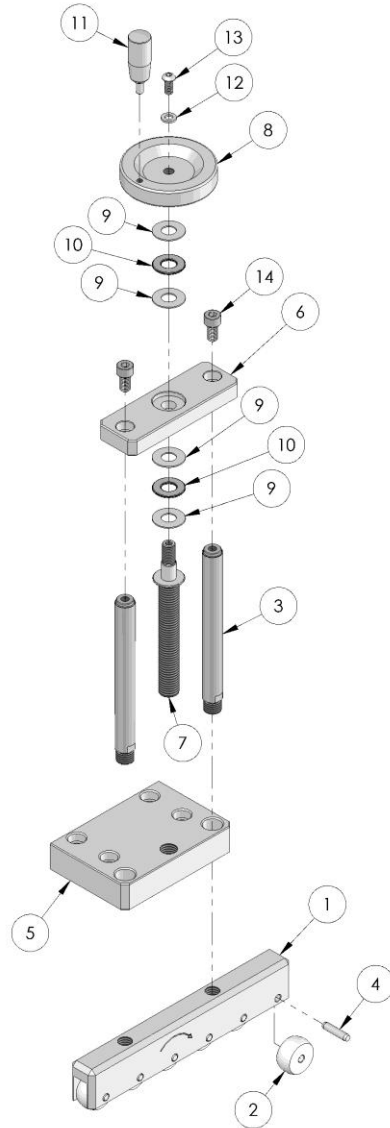

ITEM	PART NUMBER	DESCRIPTION	QTY
1	KBM-18-051	CLAMP ROLLER BLOCK	1
2	KBM-18-049	CLAMP ROLLER	6
3	KBM-18-059	SLIDE SHAFT	2
4	GK-115-088	6mm x 26mm DOWEL PIN	6
5	KBM-18-060	SLIDE SHAFT SUPPORT PLATE	1
6	KBM-18-058	SLIDE SHAFT RETAINING PLATE	1
7	KBM-18-052	SCREW SHAFT	1
8	KBM-18-057	HAND WHEEL	1
9	KBM-18-053	BEARING WASHER	4
10	KBM-18-054	THRUST BEARING	2
11	KBM-18-110	REVOLVING HANDLE	1
12	GK-111-094	WASHER 6mm BOLT x 12 OD x 1.6	1
13	GK-112-130	M6-1.0 x 14mm BHCS	1
14	GK-107-123	M8-1.25 x 16mm SHCS	2

## PIVOT ARM ASSEMBLY BREAKDOWN

Part Number: KBM-18-025

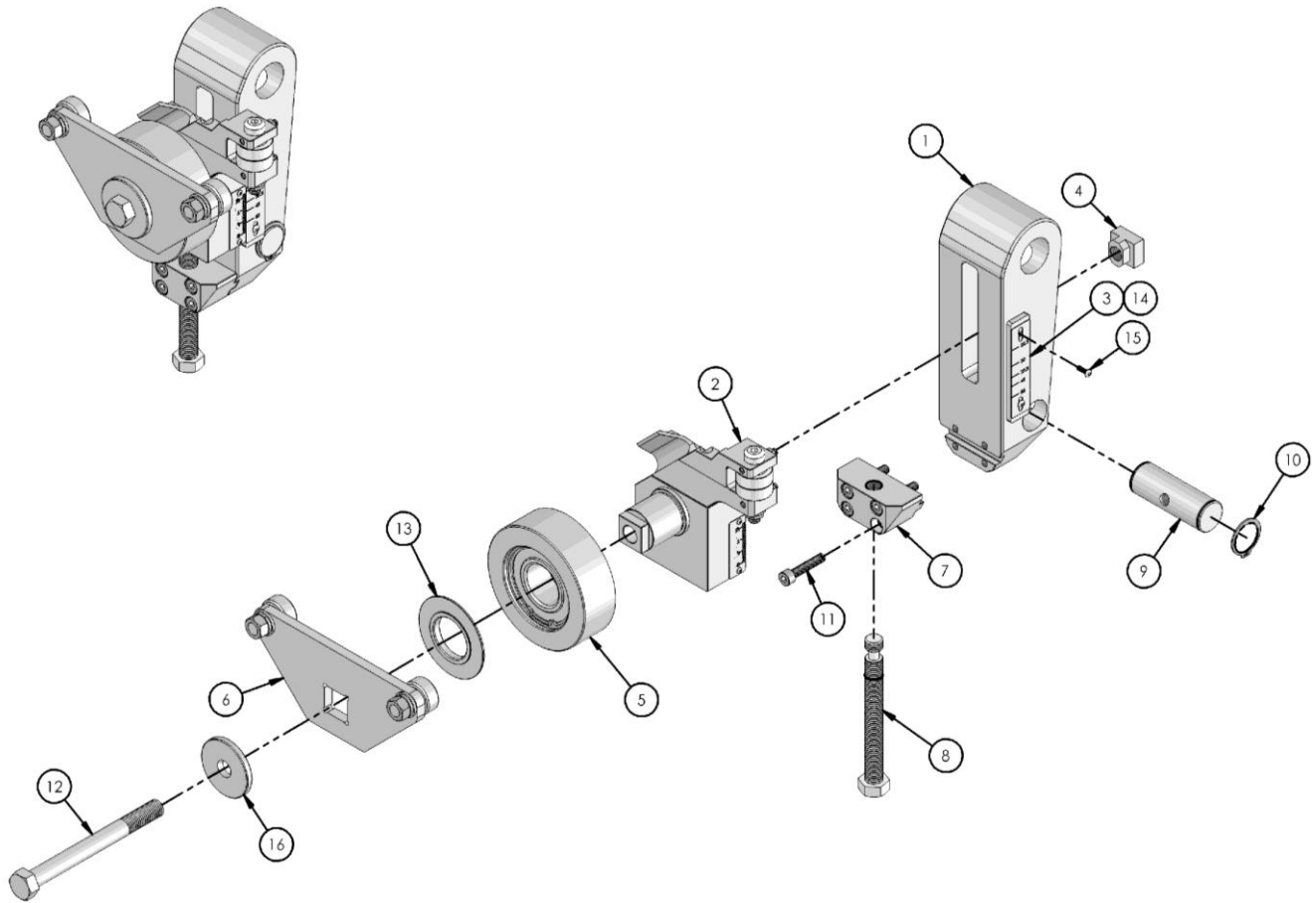

ITEM	PART NUMBER	DESCRIPTION	QTY
1	KBM-18-042	PIVOT ARM BLOCK	1
2	KBM-18-027	SLIDE BASE ASSEMBLY	1
3	KBM-18-112	ANGLE REFERENCE SCALE	1
4	KBM-18-046	T-NUT	1
5	KBM-18-026	MAIN ROLLER ASSEMBLY	1
6	KBM-18-029	SUPPORT ROLLER ASSEMBLY	1
7	KBM-18-038	ADJUSTING BOLT SUPPORT	1
8	KBM-18-039	SLIDE BASE ADJUSTING BOLT	1
9	KBM-18-043	ANGLE PIVOT PIN	1
10	GK-119-067	30MM EXT. RETAINING RING x 1.5MM	2
11	GK-107-111	M8-1.25 x 40mm SHCS	4
12	GK-108-143	M16-2 x 160mm HEX BOLT	1
13	KBM-18-097	COVER PLATE	1
14	KBM-18-021	SCALE SPACER	1
15	GK-112-117	M4-0.7 x 12mm BHCS	2
16	KBM-18-031	HEAVY DUTY WASHER	1

## SLIDE BASE ASSEMBLY BREAKDOWN

Part Number: KBM-18-027

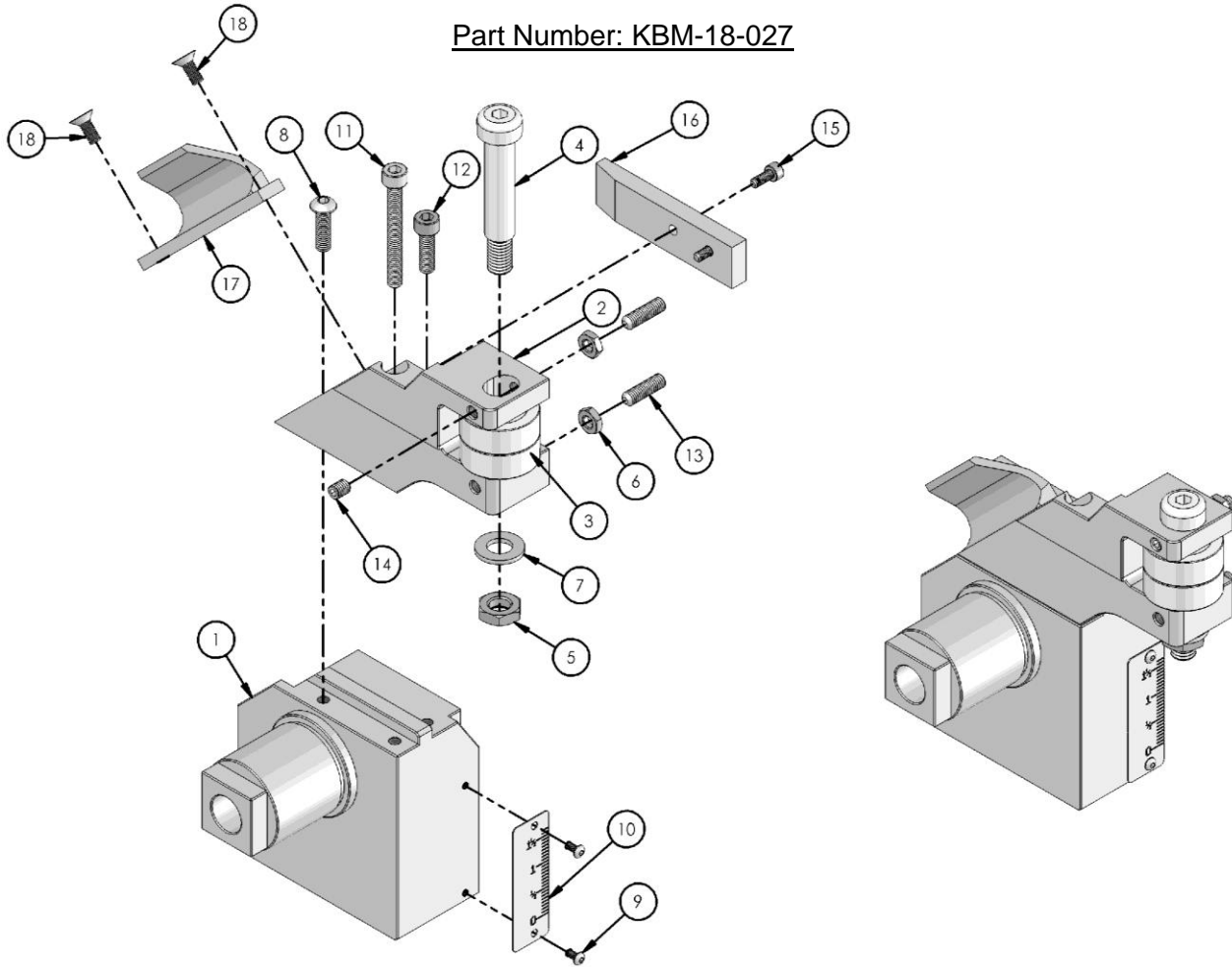

ITEM	PART NUMBER	DESCRIPTION	QTY
1	KBM-18-040	SLIDE BASE	1
2	KBM-18-063	GUIDE ROLLER BRACKET	1
3	KBM-18-064	GUIDE ROLLER	2
4	GK-104-087	12mm x 50mm SHOULDER BOLT	1
5	GK-110-070	M10 x 1.5 HEX HEAD JAM NUT	1
6	GK-110-071	M6 x 1.0 HEX HEAD JAM NUT	2
7	GK-111-096	WASHER 10mm BOLT x 20 OD x 2	1
8	GK-112-131	M6-1.0 x 20mm BHCS	1
9	GK-112-132	M3 x 6mm BHCS	2
10	KBM-18-041	ROOT FACE SCALE	1
11	GK-107-136	M6-1.0 x 50mm SHCS	1
12	GK-107-120	M6-1.0 x 20mm SHCS	1
13	GK-106-086	M6-1.0 x 20mm SET SCREW	2
14	GK-106-085	M6-1.0 x 8mm SET SCREW	1
15	GK-107-139	M4-0.7 x 10mm SHCS	2
16	KBM-18-056	CHIP DEFLECTOR SUPPORT	1
17	KBM-18-071	CHIP DEFLECTOR	1
18	GK-105-100	M5-0.8 x 12mm FHSCS	2

## MAIN ROLLER ASSEMBLY BREAKDOWN

Part Number: KBM-18-026

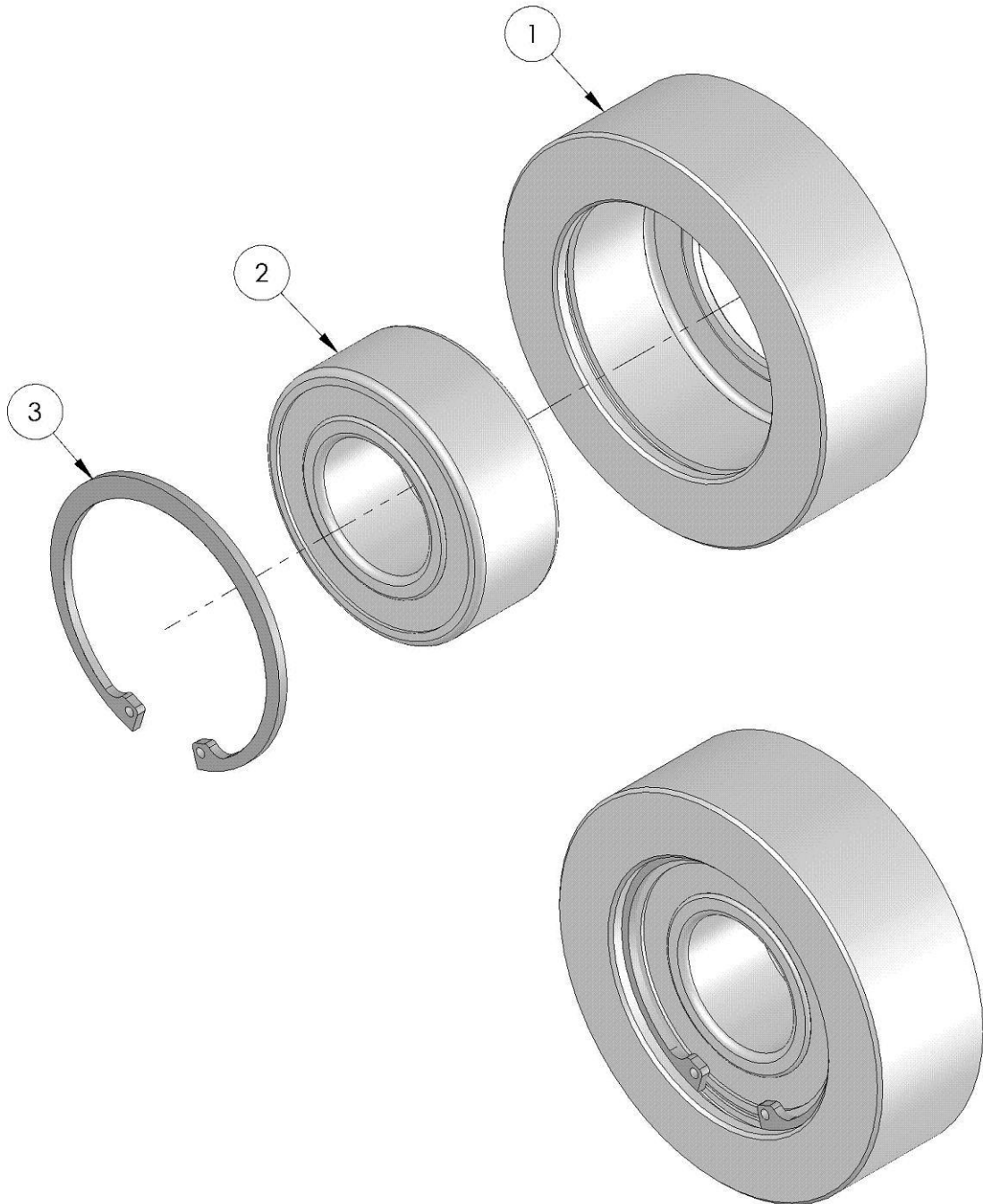

ITEM	PART NUMBER	DESCRIPTION	QTY
1	KBM-18-067	MAIN ROLLER	1
2	KBM-18-05759	MAIN ROLLER BEARING	1
3	KBM-18-05230	80mm INTERNAL RETAINING CLIP	1

## SUPPORT ROLLER ASSEMBLY BREAKDOWN

Part Number: KBM-18-029

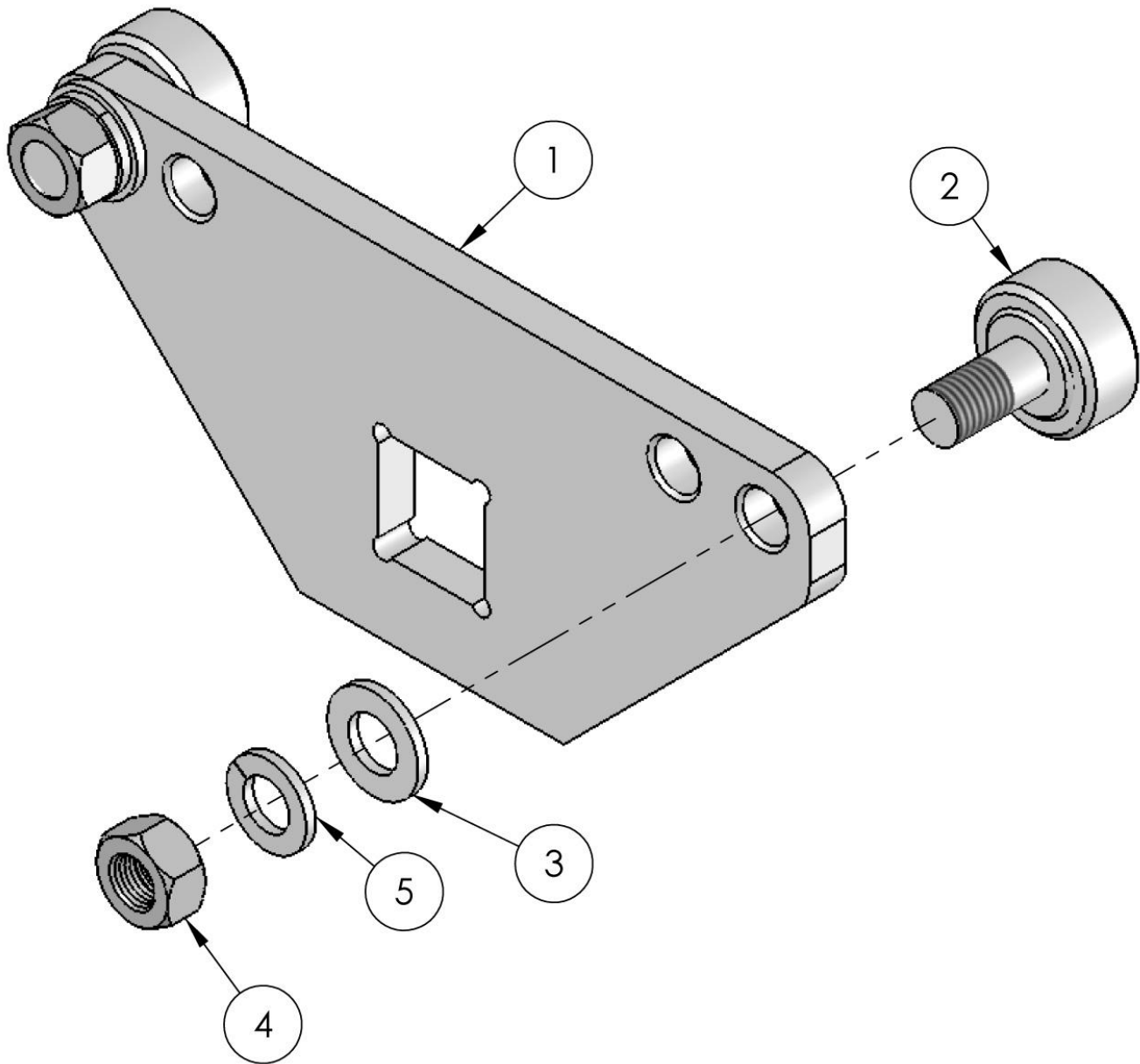

ITEM	PART NUMBER	DESCRIPTION	QTY
1	KBM-18-066	SUPPORT ROLLER PLATE	1
2	KBM-18-108	SUPPORT ROLLER	2
3	GK-111-095	WASHER 12mm BOLT x 24 OD x 2.5	2
4	GK-109-069	M12-1.5 HEX NUT	2
5	GK-136-070	LOCK WASHER 12mm BOLT	2



## STARTER ASSEMBLY BREAKDOWN

Drawing Number: KBM-18-028

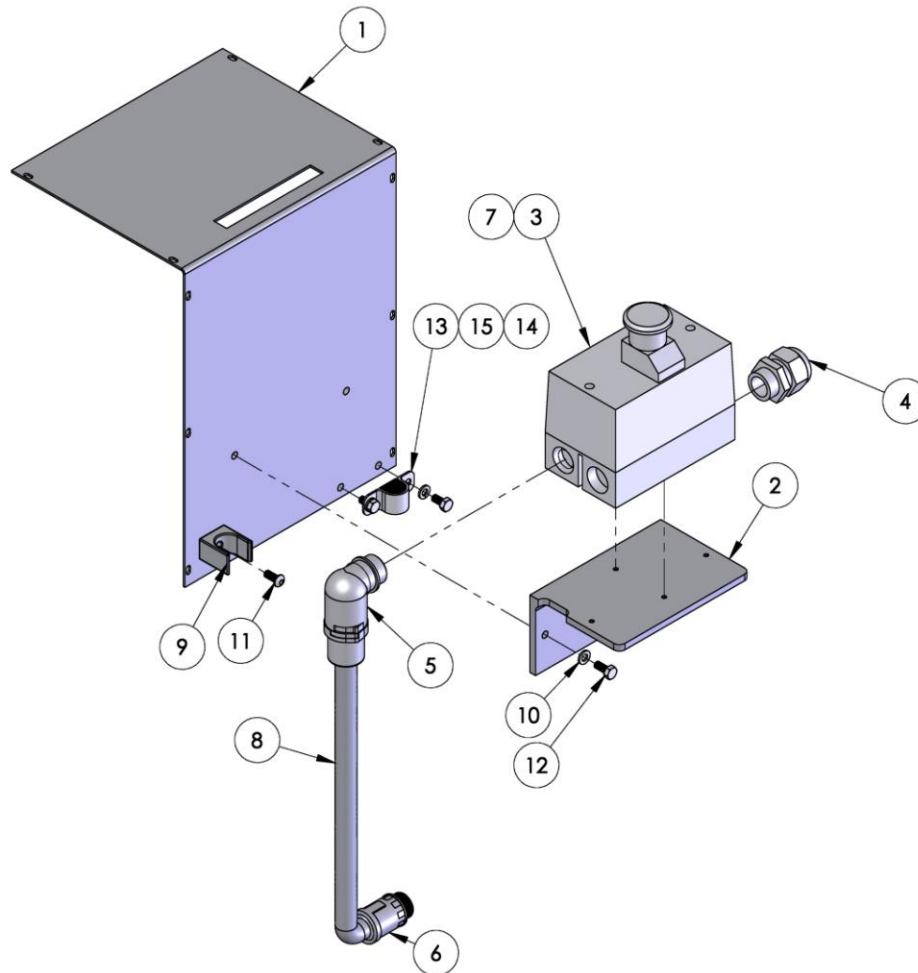

ITEM	PART NUMBER	DESCRIPTION	QTY
1	KBM-18-061	GEAR BOX COVER	1
2	KBM-18-107	STARTER MOUNTING BRACKET	1
3	GBM-18-019	MANUAL STARTER ASSEMBLY	1
4	GK-148-032	M25 CABLE GLAND	1
5	GK-148-031	M25-1.5MM 90 DEG. CONNECTOR	1
6	GK-148-025	PG16 STRAIGHT CONNECTOR	1
7	GK-107-059	#10-32UNF x 3/8 SHCS	2
8	RM-114-111	BLACK FLEX TUBE PMA	16.5"
9	GK-156-082	CO-FIX SYSTEM SUPPORT	1
10	GK-111-094	WASHER 6mm BOLT x 12 OD x 1.6	2
11	GK-112-130	M6-1.0 x 14mm BHCS	1
12	GK-108-115	M6-1.0 x 14mm HEX BOLT	2
13	GK-156-093	CABLE CLAMP	1
14	GK-108-159	M6-1.0 x 12mm HEX BOLT	2
15	GK-136-072	LOCK WASHER 6mm BOLT	2

## MANUAL STARTER ASSEMBLY BREAKDOWN

Drawing Number: GBM-18-019

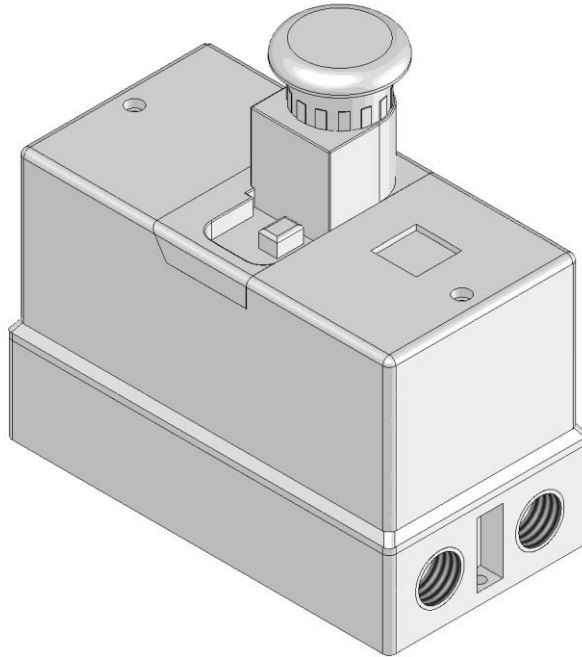

PART NUMBER	DESCRIPTION	QTY
<b>GBM-18-019-A</b>	<b>MANUAL STARTER ASSEMBLY FOR 230V MACHINES</b>	
GBM-18-019-01	ENCLOSURE	1
GBM-18-019-07	RED MUSHROOM E-STOP	1
GBM-18-019-05	MANUAL STARTER 6.3 - 10 AMP	1
GBM-18-019-08	UNDER-VOLTAGE TRIP 230V 60Hz	1
<b>GBM-18-019-B</b>	<b>MANUAL STARTER ASSEMBLY FOR 380V &amp; 400/415V MACHINES</b>	
GBM-18-019-01	ENCLOSURE	1
GBM-18-019-07	RED MUSHROOM E-STOP	1
GBM-18-019-03	MANUAL STARTER 2.5 - 4 AMP	1
GBM-18-019-09	UNDER-VOLTAGE TRIP 380V 50Hz & 415V 50Hz	1
<b>GBM-18-019-C</b>	<b>MANUAL STARTER ASSEMBLY FOR 460V MACHINES</b>	
GBM-18-019-01	ENCLOSURE	1
GBM-18-019-07	RED MUSHROOM E-STOP	1
GBM-18-019-03	MANUAL STARTER 2.5 - 4 AMP	1
GBM-18-019-10	UNDER-VOLTAGE TRIP 460V 60Hz	1
<b>GBM-18-019-D</b>	<b>MANUAL STARTER ASSEMBLY FOR 575V MACHINES</b>	
GBM-18-019-01	ENCLOSURE	1
GBM-18-019-07	RED MUSHROOM E-STOP	1
GBM-18-019-03	MANUAL STARTER 2.5 - 4 AMP	1
GBM-18-019-11	UNDER-VOLTAGE TRIP 575V 60Hz	1

## KBM®-18 MAIN GEARBOX BREAKDOWN

Part Number KBM-18-126

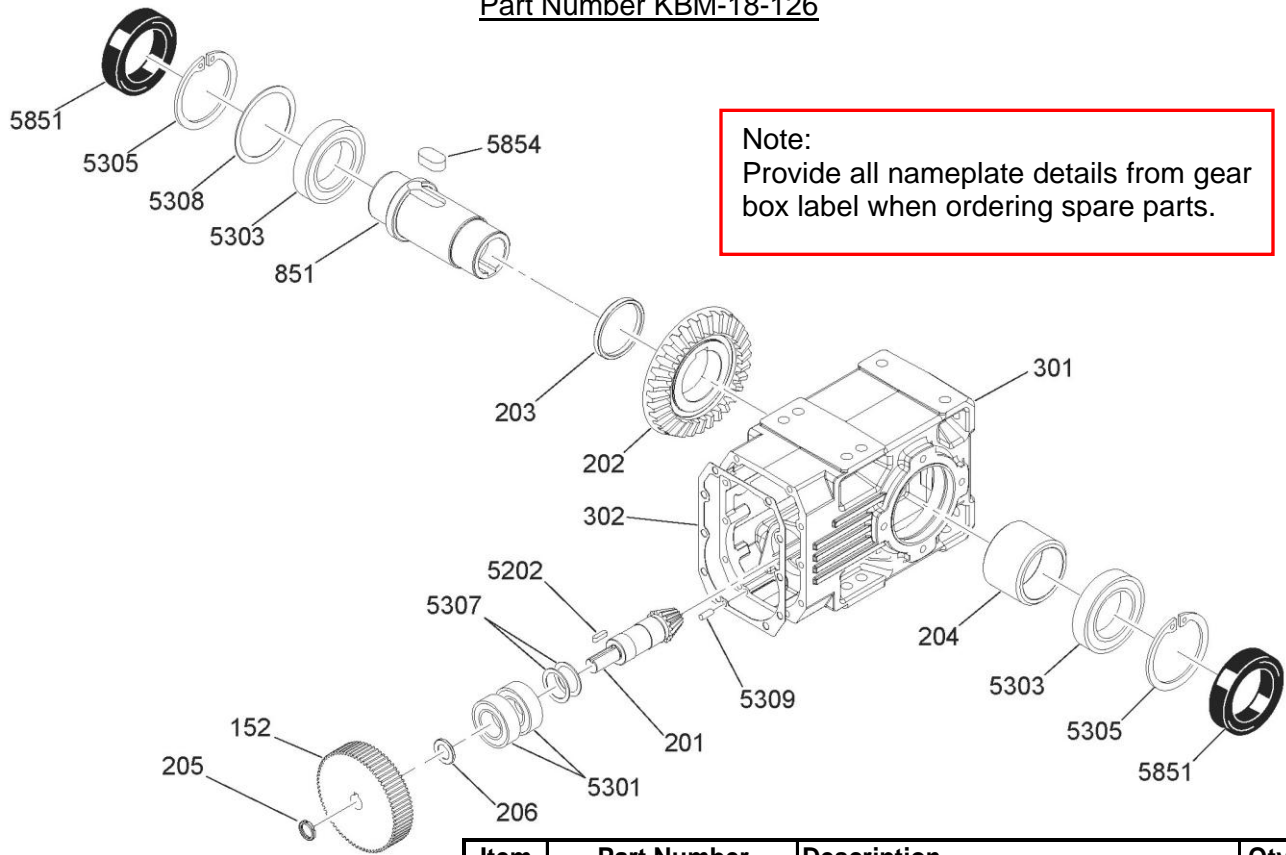

**Note:**

Provide all nameplate details from gear box label when ordering spare parts.

If component damage occurs, Gullco strongly recommends replacing the KBM-18-127 Gearbox Sub Assembly, as it is more readily available and has been precision assembled & adjusted. Special tooling and procedures are required to rebuild these gearboxes and therefore not recommended.

Item	Part Number	Description	Qty
152	KBM-18-152	Gear	1
302	KBM-18-120-GL	Gasket	1
5309	GK-115-094	Dowel Pin 6x16	2

KBM-18-127		Gearbox Sub Assembly (All Items Below)	
201	Not Sold Individually	Bevel Pinion	1
202	Not Sold Individually	Bevel Gear	1
203	Not Sold Individually	Spacer Ring	1
204	Not Sold Individually	Spacer Ring	1
205	KBM-18-205	Ring Nut M20x1.5	1
206	KBM-18-206	Spacer Ring	1
301	Not Sold Individually	Gear Housing	1
851	Not Sold Individually	Output Shaft	1
5202	KBM-18-5202	Key 6x6x25 C	1
5301	KBM-18-5301	Bearing 32007X	1
5303	KBM-18-5303	Bearing 6213	2
5305	KBM-18-5305	Circlip 120	2
5307	KBM-18-5307	Bevel Pinion Washer 35.3x48x1	1
5308	KBM-18-5308	Output Shaft Washer 100x120x1 R	1
5851	KBM-18-5851	Oil Seal 65x120x13 DL	2
5854	Not Sold Individually	Key 20x12	1

## KBM®-18 GEARBOX ADDITIONAL GEAR MODULE BREAKDOWN

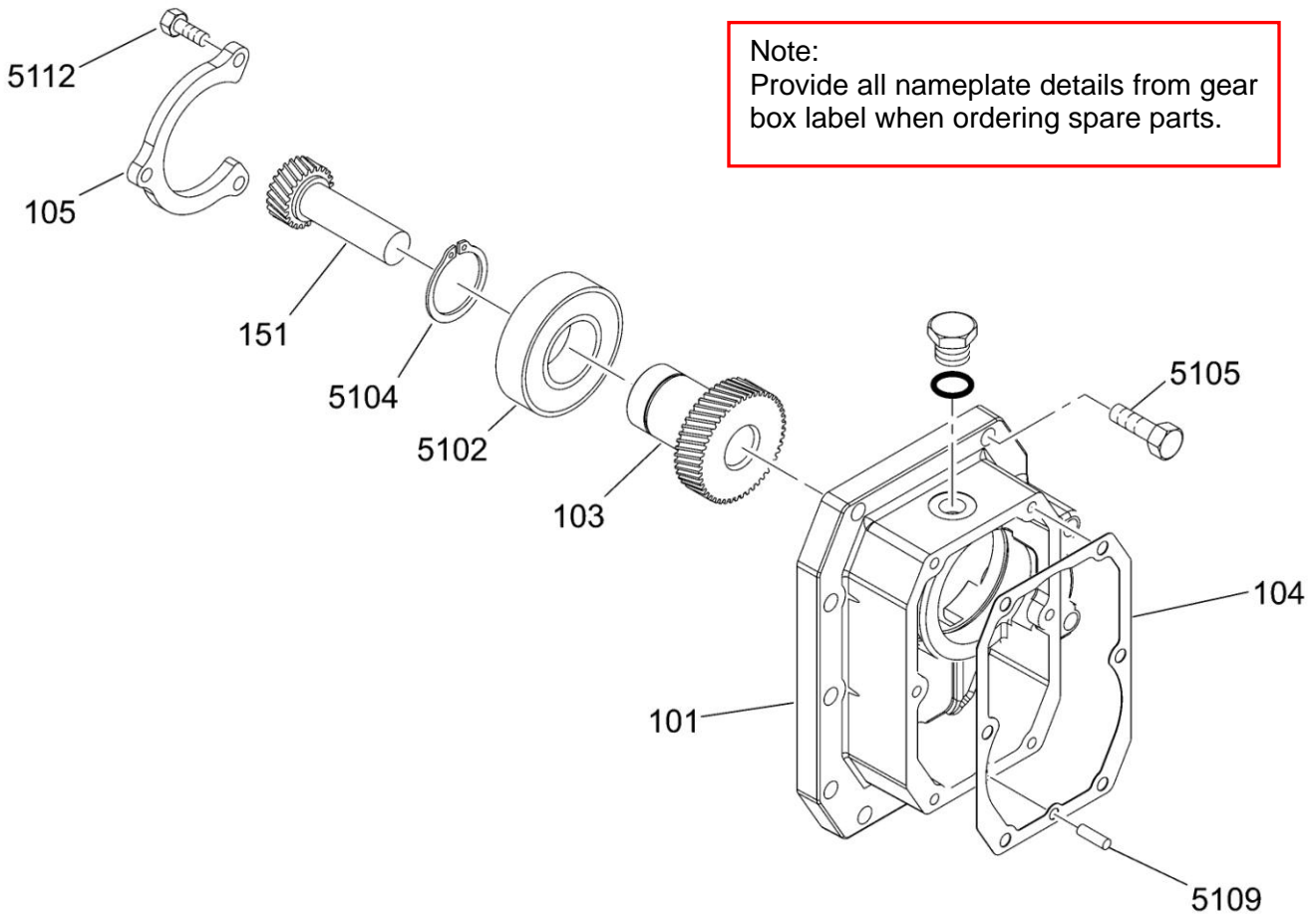

**Note:**  
Provide all nameplate details from gear box label when ordering spare parts.

If component damage occurs, Gullco strongly recommends replacing the KBM-18-201 Gear Module Assembly, as it is more readily available and has been precision assembled & adjusted. Special tooling and procedures are required to rebuild these gear modules and should only be performed by qualified technicians.

Item	Part Number	Description	Qty
104	KBM-18-120-GS	Gasket	1
151	KBM-18-151-PS	Pinion Gear	1
5105	GK-108-112	Bolt M8x25	9
	GK-108-161	Bolt M8x65	1
5109	GK-115-091	Dowel 5x16	1

	KBM-18-201	<b>Gear Module Assembly</b> (KBM-18-200 Module Sub Assy + KBM-18-151-PS Pinion Gear)	
--	------------	---	--

	KBM-18-200	<b>Additional Module Sub Assembly</b> (All items below)	
101	KBM-18-141	Additional Gear Module	1
103	KBM-18-142	Gear	1
105	KBM-18-143	Bearing Retainer	1
5102	KBM-18-144	Bearing 3206-2RS	1
5104	GK-119-072	External Retaining Clip 30	1
5112	GK-108-122	Bolt T.E. M6x16	3

## KBM®-18 MOTOR ASSEMBLY BREAKDOWN

Note:  
Provide all nameplate details from gear box label when ordering spare parts.

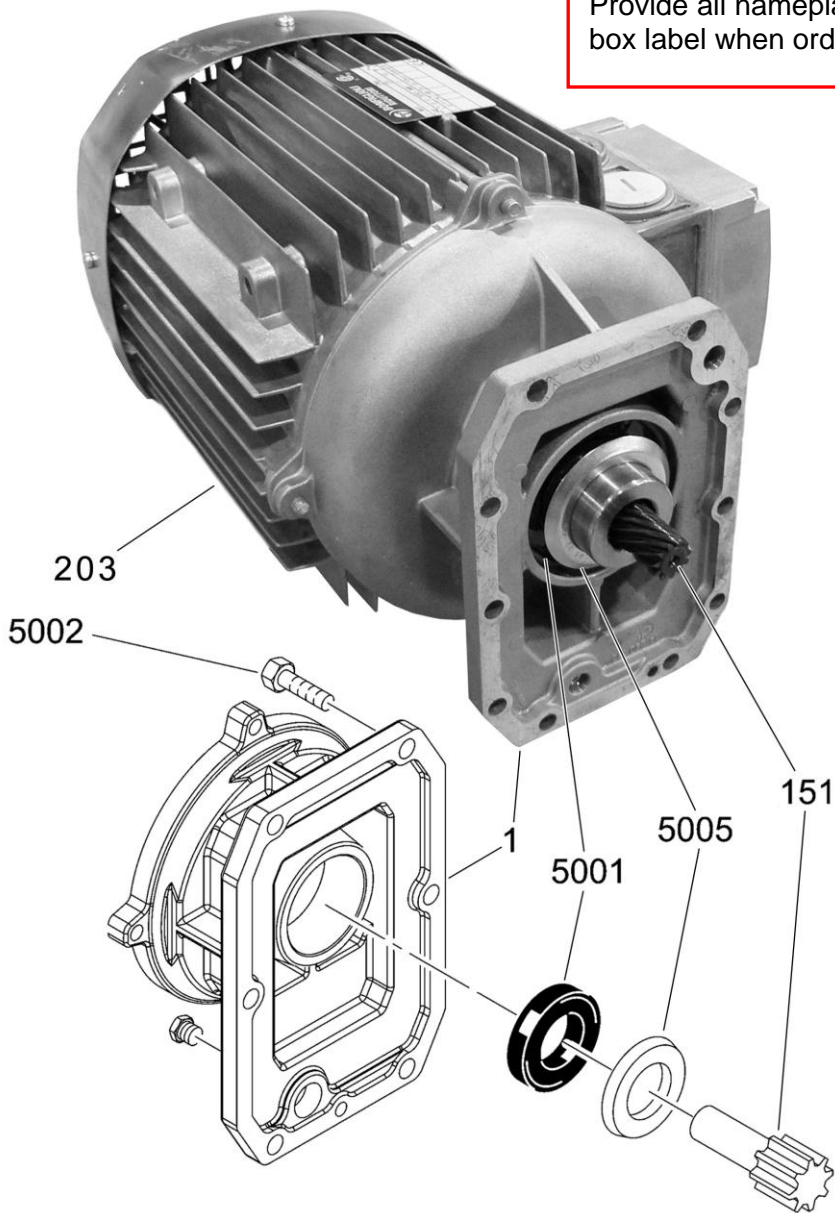

Item	Part Number	Description	Qty
203	KBM-18-203-A	230/460V Motor Assembly (KBM-18-100-A, -B, -C & D) Includes items 1, 151, 5001 & 5005	1
	KBM-18-203-B	575V Motor Assembly (KBM-18-100-E) Includes items 1, 151, 5001 & 5005	
1	KBM-18-207	Cover	1
151	Not Sold Individually	Pinion Gear	1
5001	KBM-18-5001	Oil Seal	1
5002	KBM-18-5002	Bolt 6 x 20	10
5005	KBM-18-5005	Gamma Seal	1

## OPTIONAL UNDERCARRIAGE ASSEMBLY BREAKDOWN

Part Number: KBM-18-069

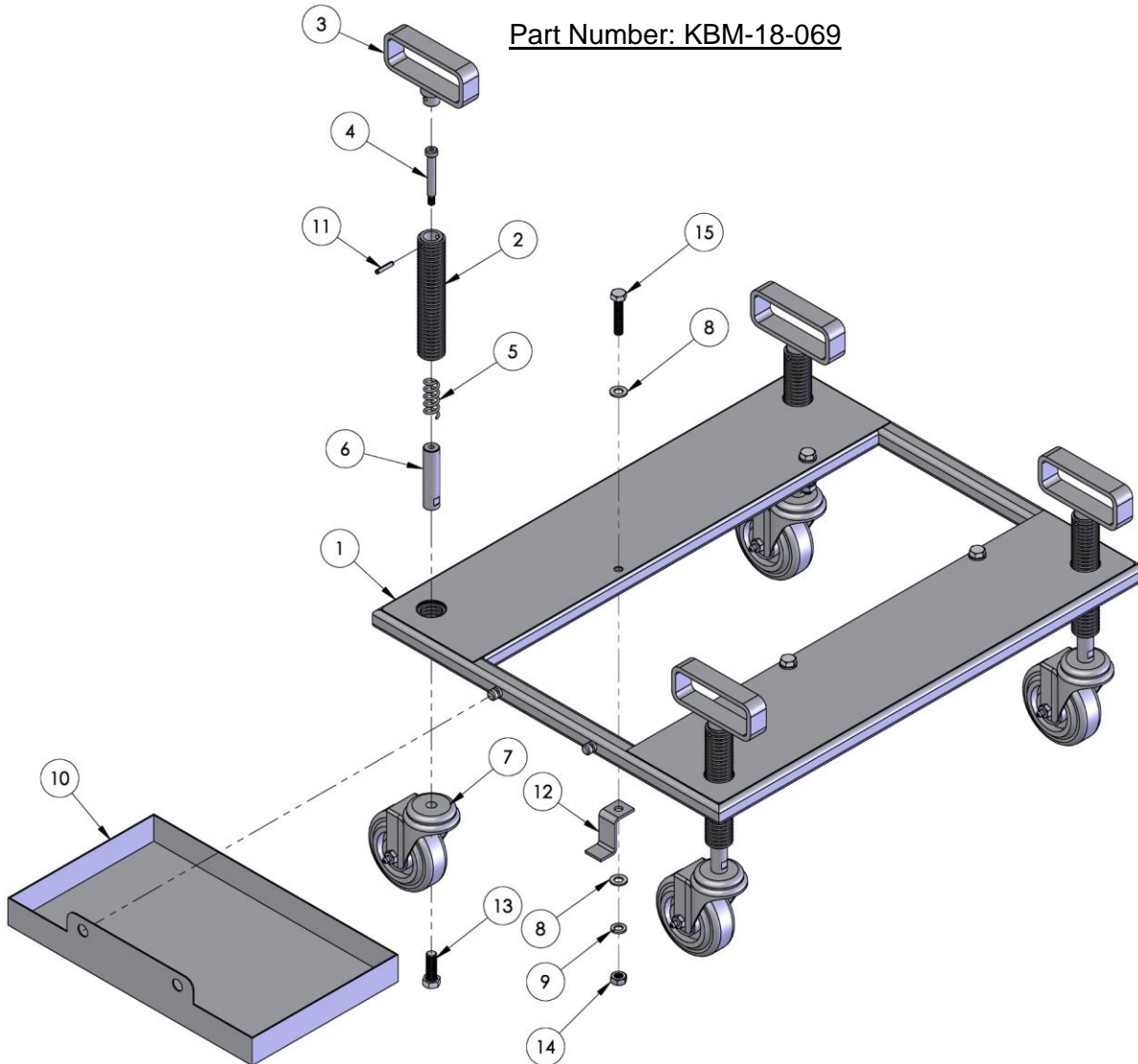

ITEM	PART NUMBER	DESCRIPTION	QTY
1	KBM-18-089	BASE FRAME	1
2	GBM-18-084	HEIGHT ADJUSTMENT SCREW	4
3	GBM-18-086	HANDLE	4
4	GK-104-075	3/8 x 2-1/4 SHOULDER BOLT	4
5	GK-116-022	SPRING	4
6	GBM-18-087	CASTER PIN	4
7	GBM-18-093	SWIVEL CASTER	4
8	GK-111-096	WASHER 10mm BOLT x 20 OD x 2	8
9	GK-136-069	LOCK WASHER 10mm BOLT	4
10	GBM-18-092	CHIP TRAY	1
11	GK-117-026	3/16 x 1 SPRING PIN	4
12	GBM-18-091	CHIP TRAY MOUNTING BRACKET	2
13	GK-108-134	M12-1.75 x 35mm HEX BOLT	4
14	GK-109-075	M10-1.5 HEX NUT	4
15	GK-108-124	M10-1.5 x 50mm HEX BOLT	4