

RANGER 305D CE

OPERATOR'S MANUAL

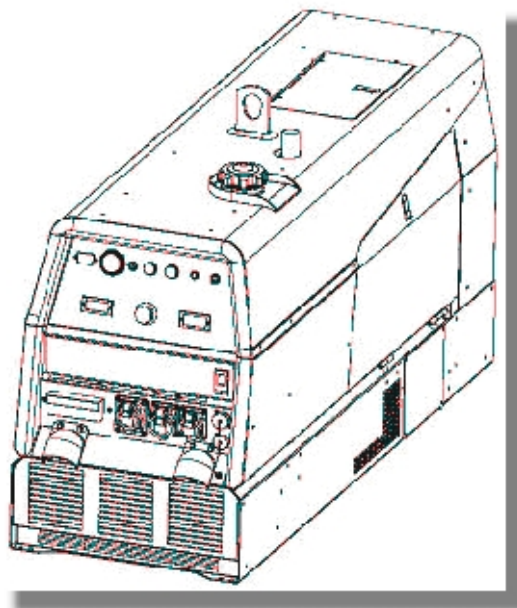

THE LINCOLN ELECTRIC COMPANY
22801 St. Clair Ave., Cleveland Ohio 44117-1199 USA
www.lincolnelectric.eu

THE LINCOLN ELECTRIC COMPANY

EC DECLARATION OF CONFORMITY



Manufacturer and technical documentation holder:

The Lincoln Electric Company
22801 St. Clair Ave.
Cleveland Ohio 44117-1199 USA

EC Company:

Lincoln Electric Europe S.L.
c/o Balmes, 89 - 80 2a
08008 Barcelona SPAIN

Hereby declare that welding equipment:

Ranger 305D with CE marking

Product number:

K2279 (may contain prefixes and suffixes)

Is in conformity with Council Directives and amendments:

Machinery Directive 2006/42/EC;
Low Voltage Directive 2014/35/EU
Electromagnetic Compatibility (EMC) Directive 2014/30/EU
Noise emission in the environment by equipment for use outdoors
2000/14/EC.

EN 60974-1:2012, Safety requirements for arc welding equipment, power sources;
EN 60974-10:2014, Arc Welding Equipment-Part 10: Electromagnetic compatibility (EMC) requirements;
EN ISO 3744:2010, Acoustics – Determination of sound power levels of noise sources using sound pressure ... reflecting plane;
EN 60204-1:2006, Safety of machinery – Electrical equipment of machines, Part 1: General requirements;
EN 12100:2010, Safety of machinery – General principles for design risk assessment and risk reduction.

Notified body (for 2000/14/EC Conformity):

LNE – Number: 0071
ZA de Trappes-Élancourt
29, avenue Roger Hennequin
78197 TRAPPES Cedex

Guaranteed sound power level:

LWA 97 dB (net power P_{el} = 7.5 kW)

Measured sound power level:

LWA 96 dB (net power P_{el} = 7.5 kW)

CE marking affixed in '15

Handwritten signature of Samir Farah in black ink, written over a horizontal line.

Samir Farah, Manufacturer
Compliance Engineering Manager

7 September 2017

Handwritten signature of Jacek Stefaniak in black ink, written over a horizontal line.

Jacek Stefaniak, European Community Representative
European Product Manager Equipment

8 September 2017

MCD40e



12/05

THANKS! For having chosen the QUALITY of the Lincoln Electric products.

- Please Examine Package and Equipment for Damage. Claims for material damaged in shipment must be notified immediately to the dealer.
- For future reference record in the table below your equipment identification information. Model Name, Code & Serial Number can be found on the machine rating plate.

Model Name:	
.....	
Code & Serial number:	
.....
Date & Where Purchased:	
.....

ENGLISH INDEX

Technical Specifications.....	1
Electromagnetic Compatibility (EMC).....	2
Safety.....	3
Installation and Operator Instructions.....	4
Diagrams.....	17
WEEE.....	22
Spare Parts.....	22
Authorized Service Shops Location.....	22
Electrical Schematic.....	22

Technical Specifications

RANGER® 305D (CE) (K2279-1, K2279-2, K2279-3)

INPUT – DIESEL ENGINE					
Model	Description	Speed (RPM)	Displacement (cu. cm)	Starting System	Capacities
Kubota ⁽³⁾ D722	3 cylinder, 4 stroke 15.9 HP (12KW) Net intermittent 3000 RPM naturally aspirated water cooled Diesel engine	High Idle 3100	789	12VDC Battery & Starter (Group 58: 550 cold crank amps) Battery Charger (3.6L)	Fuel: 45L Oil: 3.2L Radiator Coolant: 3.6L
		Full Load 3000	Bore x Stroke (mm)		
		Low Idle 2200	67x 68		
RATED OUTPUT @ 40°C - WELDER					
Welding Process	Welding Output Current/Voltage/Duty Cycle		Output Range	Max. Weld OCV @ Rated Load RPM	
DC Constant Current DC Pipe Current Touch-Start® TIG DC Constant Voltage	250A / 30V / 100% 250A / 30V / 100% 250A / 20V / 100% 250A / 27V / 100%		20 to 305A 40 to 300A 20 to 250A 14 to 29V	60V	
RATED OUTPUT @ 40°C - GENERATOR					
Auxiliary Power ⁽¹⁾					
8500 Watts Peak / 8000Watts Continuous, 50 Hz , 230V/400V, 3Phase					
Sound Level					
Sound Power: 97dB Lwa					
PHYSICAL DIMENSIONS					
Height 909 mm ⁽²⁾	Width 546 mm	Length 1524 mm	Weight 341kg		
ENGINE					
Lubrication	Emission	Fuel System		Governor	
Full pressure with full flow filter	Certified to EPA Tier 4 Compliant	Mechanical fuel pump, Auto air bleed system Electric shutoff solenoid indirect fuel injector.		Mechanical governor	
Air Cleaner	Engine Idler	Muffler		Engine Protection	
Single element	Automatic idler	Low noise muffler: made from long life, aluminized steel.		Shutdown on low oil pressure & engine temperature	
ENGINE WARRANTY: 2 year complete (parts and labor) 3rd. year major components (parts and labor) ⁽³⁾					

DESCRIPTION		
MODEL NUMBER	K2279-1, K2279-3 (UK)	K2279-2 (Europe)
Receptacles	400V (3 Ph) x 1 230V (1 Ph) x 1 115V x 1 ⁽⁴⁾ 14 Pin Connector 6 Pin Connector	400V (3 Ph) x 1 230V (1 Ph) x 2 14 Pin Connector 6 Pin Connector
Residual Current Device (RCD)	4-pole, 25 Amp (30mA trip current)	4-pole, 25 Amp (30mA trip current)
Circuit Breakers (Thermal/Magnetic)	3 Phase, 20 Amp x 1 1 Phase, 15 Amp x 5	3 Phase, 20 Amp x 1 1 Phase, 15 Amp x 4

⁽¹⁾ Output rating in watts is equivalent to volt-amperes at unity power factor. Output voltage is within ± 10% at all loads up to rated capacity. When welding, available auxiliary power will be reduced.

⁽²⁾ To top of enclosure, add 152mm (6 ") to top of exhaust elbow.

⁽³⁾ Engine warranty may vary outside of the USA. (See Engine warranty for details)

⁽⁴⁾ Center-Tapped to ground.

Electromagnetic Compatibility (EMC)

This machine has been designed in accordance with all relevant directives and standards. However, it may still generate electromagnetic disturbances that can affect other systems like telecommunications (telephone, radio, and television) or other safety systems. These disturbances can cause safety problems in the affected systems. Read and understand this section to eliminate or reduce the amount of electromagnetic disturbance generated by this machine.



This machine has been designed to operate in an industrial area. The operator must install and operate this equipment as described in this manual. If any electromagnetic disturbances are detected the operator must put in place corrective actions to eliminate these disturbances with, if necessary, assistance from Lincoln Electric. This equipment does not comply with IEC 61000-3-12. If it is connected to a public low-voltage system, it is responsibility of the installer or user of the equipment to ensure, by consultation with the distribution network operator if necessary, that the equipment may be connected.

Before installing the machine, the operator must check the work area for any devices that may malfunction because of electromagnetic disturbances. Consider the following.

- Input and output cables, control cables, and telephone cables that are in or adjacent to the work area and the machine.
- Radio and/or television transmitters and receivers. Computers or computer controlled equipment.
- Safety and control equipment for industrial processes. Equipment for calibration and measurement.
- Personal medical devices like pacemakers and hearing aids.
- Check the electromagnetic immunity for equipment operating in or near the work area. The operator must be sure that all equipment in the area is compatible. This may require additional protection measures.
- The dimensions of the work area to consider will depend on the construction of the area and other activities that are taking place.

Consider the following guidelines to reduce electromagnetic emissions from the machine.

- Connect the machine to the input supply according to this manual. If disturbances occur it may be necessary to take additional precautions such as filtering the input supply.
- The output cables should be kept as short as possible and should be positioned together. If possible connect the work piece to ground in order to reduce the electromagnetic emissions. The operator must check that connecting the work piece to ground does not cause problems or unsafe operating conditions for personnel and equipment.
- Shielding of cables in the work area can reduce electromagnetic emissions. This may be necessary for special applications.

WARNING

The Class A equipment is not intended for use in residential locations where the electrical power is provided by the public low-voltage supply system. There can be potential difficulties in ensuring electromagnetic compatibility in those locations, due to conducted as well as radio-frequency disturbances.









WARNING

This equipment must be used by qualified personnel. Be sure that all installation, operation, maintenance and repair procedures are performed only by qualified person. Read and understand this manual before operating this equipment. Failure to follow the instructions in this manual could cause serious personal injury, loss of life, or damage to this equipment. Read and understand the following explanations of the warning symbols. Lincoln Electric is not responsible for damages caused by improper installation, improper care or abnormal operation.

	<p>WARNING: This symbol indicates that instructions must be followed to avoid serious personal injury, loss of life, or damage to this equipment. Protect yourself and others from possible serious injury or death.</p>
	<p>READ AND UNDERSTAND INSTRUCTIONS: Read and understand this manual before operating this equipment. Arc welding can be hazardous. Failure to follow the instructions in this manual could cause serious personal injury, loss of life, or damage to this equipment.</p>
	<p>ELECTRIC SHOCK CAN KILL: Welding equipment generates high voltages. Do not touch the electrode, work clamp, or connected work pieces when this equipment is on. Insulate yourself from the electrode, work clamp, and connected work pieces.</p>
	<p>ELECTRICALLY POWERED EQUIPMENT: Turn off input power using the disconnect switch at the fuse box before working on this equipment. Ground this equipment in accordance with local electrical regulations.</p>
	<p>ELECTRICALLY POWERED EQUIPMENT: Regularly inspect the input, electrode, and work clamp cables. If any insulation damage exists replace the cable immediately. Do not place the electrode holder directly on the welding table or any other surface in contact with the work clamp to avoid the risk of accidental arc ignition.</p>
	<p>ELECTRIC AND MAGNETIC FIELDS MAY BE DANGEROUS: Electric current flowing through any conductor creates electric and magnetic fields (EMF). EMF fields may interfere with some pacemakers, and welders having a pacemaker shall consult their physician before operating this equipment.</p>
	<p>CE COMPLIANCE: This equipment complies with the European Community Directives.</p>
	<p>FUMES AND GASES CAN BE DANGEROUS: Welding may produce fumes and gases hazardous to health. Avoid breathing these fumes and gases. To avoid these dangers the operator must use enough ventilation or exhaust to keep fumes and gases away from the breathing zone.</p>
	<p>ARC RAYS CAN BURN: Use a shield with the proper filter and cover plates to protect your eyes from sparks and the rays of the arc when welding or observing. Use suitable clothing made from durable flame-resistant material to protect you skin and that of your helpers. Protect other nearby personnel with suitable, non-flammable screening and warn them not to watch the arc nor expose themselves to the arc.</p>
	<p>WELDING SPARKS CAN CAUSE FIRE OR EXPLOSION: Remove fire hazards from the welding area and have a fire extinguisher readily available. Welding sparks and hot materials from the welding process can easily go through small cracks and openings to adjacent areas. Do not weld on any tanks, drums, containers, or material until the proper steps have been taken to insure that no flammable or toxic vapors will be present. Never operate this equipment when flammable gases, vapors or liquid combustibles are present.</p>
	<p>WELDED MATERIALS CAN BURN: Welding generates a large amount of heat. Hot surfaces and materials in work area can cause serious burns. Use gloves and pliers when touching or moving materials in the work area.</p>
	<p>SAFETY MARK: This equipment is suitable for supplying power for welding operations carried out in an environment with increased hazard of electric shock.</p>

	CYLINDER MAY EXPLODE IF DAMAGED: Use only compressed gas cylinders containing the correct shielding gas for the process used and properly operating regulators designed for the gas and pressure used. Always keep cylinders in an upright position securely chained to a fixed support. Do not move or transport gas cylinders with the protection cap removed. Do not allow the electrode, electrode holder, work clamp or any other electrically live part to touch a gas cylinder. Gas cylinders must be located away from areas where they may be subjected to physical damage or the welding process including sparks and heat sources.
	MOVING PARTS can injure. Do not operate with doors open or guards off. Stop engine before servicing. Keep away from moving parts. Keep all equipment safety guards, covers and devices in position and in good repair. Keep hands, hair, clothing and tools away from V-belts, gears, fans and all other moving parts when starting, operating or repairing equipment.
	Do not add the fuel near an open flame welding arc or when the engine is running. Stop the engine and allow it to cool before refueling to prevent spilled fuel from vaporizing on contact with hot engine parts and igniting. Do not spill fuel when filling tank. If fuel is spilled, wipe it up and do not start engine until fumes have been eliminated.
	To avoid scalding, do not remove the radiator pressure cap when the engine is hot.

Installation and Operator Instructions

Read this entire section before installation or operation of the machine.

WARNING

Do not attempt to use this equipment until you have thoroughly read the engine manufacturer's manual supplied with your welder. It includes important safety precautions, detailed engine starting, operating and maintenance instructions, and parts lists.



ELECTRIC SHOCK can kill:

- Do not touch electrically live parts or electrode with skin or wet clothing.
- Insulate yourself from work and ground
- Always wear dry insulating gloves.



ENGINE EXHAUST can kill:

- Use in open, well ventilated areas or vent exhaust outside.



MOVING PARTS can injure:

- Do not operate with doors open or guards off.
- Stop engine before servicing.
- Keep away from moving parts

See additional warning information at front of this operator's manual.

Only qualified personnel should install, use, or service this equipment.

General Description

The RANGER 305D (CE) is a diesel engine powered DC multi-process welding power source and AC power

generator. The engine drives a generator that supplies three-phase power for the DC welding circuit and three-phase and single-phase power for the AC auxiliary outlets. The DC welding control system uses state of the art Chopper Technology (CT™) for superior welding performance.

Location and Ventilation

The welder should be located to provide an unrestricted flow of clean, cool air to the cooling air inlets and to avoid restricting the cooling air outlets. Also, locate the welder so that the engine exhaust fumes are properly vented to an outside area.

Stacking

RANGER 305D (CE) machines cannot be stacked.

Angle of Operation

Engines are designed to run in the level condition which is where the optimum performance is achieved. The maximum angle of continuous operation is 20 degrees in all directions, 35 degrees Intermittent (less than 10 minutes continuous) in all directions. If the engine is to be operated at an angle, provisions must be made for checking and maintaining the oil level at the normal (FULL) oil capacity in the crankcase.

When operating the welder at an angle, the effective fuel capacity will be slightly less than the specified 45 liters (12 gallons).

Lifting

The machine weighs approximately 374 kg. (824 lbs) with a full tank of fuel. A lift bail is mounted to the machine and should always be used when lifting the machine.



WARNING

Falling equipment can cause injury.

- Lift only with equipment of adequate lifting capacity.
- Be sure machine is stable when lifting.
- Do not lift this machine using lift bail if it is equipped with a heavy accessory such as trailer or gas cylinder.
- Do not lift machine if lift bail is damaged.
- Do not operate machine while suspended from lift bail.

High Altitude Operation

At higher altitudes, output derating may be necessary. For maximum rating, derate the machine 2.5% to 3.5% for every 305m (1000ft.). Due to new EPA and other local emissions regulations, modifications to the engine for high altitude are restricted within the United States and some European Countries. Use above 1828m (6000 ft.) may be limited due to poor engine performance or excessive exhaust smoke. An authorized Kubota engine field service shop should be contacted to determine if any adjustments can be made for operation in higher elevations locally.

High Temperature Operation

At temperatures above 40°C, welder output derating is necessary. For maximum output ratings, derate the welder output 2 volts for every 10°C above 40°C

Cold Weather Starting

With a fully charged battery and the proper oil, the engine should start satisfactorily down to about -15°C. If the engine must be frequently started at or below -5°C, it may be desirable to install cold starting aides. The use of No. 1D diesel fuel is recommended in place of No. 2D at temperatures below -5°C. Allow the engine to warm up before applying a load or switching to high idle.

WARNING

NOTE: Extreme cold weather starting may require longer glow plug operation. Under no conditions should ether or other starting fluids be used!

Towing

Check with distributor for the recommended trailer for use with this equipment for road, in-plant and yard towing by a vehicle. If the user adapts a non-Lincoln trailer, he must assume responsibility that the method of attachment and usage does not result in a safety hazard nor damage the welding equipment. Some of the factors to be considered are as follows:

- Design capacity of trailer vs. weight of Lincoln equipment and likely additional attachments.
- Proper support of, and attachment to, the base of the welding equipment so there will be no undue stress to the framework.
- Proper placement of the equipment on the trailer to insure stability side to side and front to back when being moved and when standing by itself while being operated or serviced.
- Typical conditions of use, i.e., travel speed;

roughness of surface on which the trailer will be operated; environmental conditions; like maintenance.

- Conformance with laws in nation / region to be used.

Vehicle Mounting

WARNING

Improperly mounted concentrated loads may cause unstable vehicle handling and tires or other components to fail.

- Only transport this Equipment on serviceable vehicles which are rated and designed for such loads.
- Distribute, balance and secure loads so vehicle is stable under conditions of use.
- Do not exceed maximum rated loads for components such as suspension, axles and tires.
- Mount equipment base to metal bed or frame of vehicle.
- Follow vehicle manufacturer's instructions.

Pre-Operation Engine Service

Read the engine operating and maintenance instructions supplied with this machine.

WARNING

- Stop engine and allow to cool before fueling.
- Do not smoke when fueling.
- Fill fuel tank at a moderate rate and do not overfill.
- Wipe up spilled fuel and allow fumes to clear before starting engine.
- Keep sparks and flame away from tank.

Oil



The machine is shipped with the engine crankcase filled with high quality SAE 10W-30 Oil that meets classification CG-4 or CH-4 for diesel engines. Check the oil level before starting the engine. If it is not up to the full mark on the dip stick, add oil as required. Check the oil level every four hours of running time during the first 50 running hours. Refer to the engine Operator's Manual for specific oil recommendations and break-in information. The oil change interval is dependent on the quality of the oil and the operating environment. Refer to the Engine Operator's Manual for more details on the proper service and maintenance intervals.

Fuel



Use Diesel fuel only.

WARNING

Fill the fuel tank with clean, fresh fuel. The capacity of the tank is about 45 l.

WARNING

NOTE: A fuel shut off valve is located on the prefilter/sediment filter. Which should be in the closed position when the welder is not operated for extended periods of time.

Engine Cooling System

WARNING

Air to cool the engine is drawn in the base sides and exhaust through radiator & case back. It is important that the intake and exhaust air is not restricted. Allow a minimum clearance of 0.6m from the case back and 40cm from either side of the base to a vertical surface.

Battery Connection

WARNING

Use caution as the electrolyte is a strong acid that can burn skin and damage eyes.

The machine is shipped with the negative battery cable disconnected. Make certain that the RUN-STOP switch is in the STOP position. Attach the negative battery cable to the negative battery terminal and tighten using a 13mm socket or wrench. It may be helpful to remove the coolant over-fill bottle. Pull up on bottle to remove from bracket.

Note: This machine is furnished with a wet charged battery; if unused for several months, the battery may require a booster charge. Be careful to charge the battery with the correct polarity.

Muffler Outlet / Spark Arrestor

In addition to operating as a Spark Arrestor. The Spark Arrestor serves as an outlet cover for the muffler as well as providing additional sound reduction. Remove from the box and install using the clamp and instructions provided. An incorrect spark arrestor may lead to damage to the engine or adversely affect performance.

WARNING

An incorrect spark arrestor may lead to damage to the engine or adversely affect performance.

Remote Control

The machine is equipped with a 6-pin and a 14-pin connector. The 6-pin connector is for connecting the K857 or K857-1 Remote Control or for TIG welding, the K870 foot Amptrol or the K963-3 hand Amptrol. When in the CC-STICK, DOWNHILL PIPE, or CVWIRE modes and when a remote control is connected to the 6-pin Connector, the auto-sensing circuit automatically switches the OUTPUT control from control at the welder to remote control.

When in TOUCH START TIG mode and when an Amptrol is connected to the 6-Pin Connector, the OUTPUT dial is used to set the maximum current range of the CURRENT CONTROL of the Amptrol.

The 14-pin connector is used to directly connect a wire feeder control cable. In the CV-WIRE mode, when the control cable is connected to the 14-pin connector, the auto-sensing circuit automatically makes the Output Control inactive and the wire feeder voltage control active.

WARNING

NOTE: When a wire feeder with a built in welding voltage control is connected to the 14-pin connector, do not connect anything to the 6-pin connector.

Electrical Connections

Machine Grounding



Because this portable engine driven welder creates its own power, it is not necessary to connect its frame to an earth ground, unless the machine is connected to premises wiring (home, shop, etc.).

To prevent dangerous electric shock, other equipment to which this engine driven welder supplies power must:

WARNING

- Be grounded to the frame of the welder using a grounded type plug.
- Be double insulated.
- Do not ground the machine to a pipe that carries explosive or combustible material.

When this welder is mounted on a truck or trailer, its frame must be electrically bonded to the metal frame of the vehicle. Use a #8 or larger copper wire connected between the machine grounding stud and the frame of the vehicle. When this engine driven welder is connected to premises wiring such as that in a home or shop, its frame must be connected to the system earth ground. See further connection instructions in the section entitled "Standby Power Connections".

In general, if the machine is to be grounded, it should be connected with a #8 or larger copper wire to a solid earth ground such as a metal water pipe going into the ground for at least ten feet and having no insulated joints, or to the metal framework of a building which has been effectively grounded.

A machine grounding stud marked with the symbol  is provided on the front of the welder.

Welding Terminals

The machine is equipped with a toggle switch for selecting "hot" welding terminal when in the "WELD TERMINALS ON" position or "cold" welding terminal when in the "REMOTE" position.

Welding Output Cables

With the engine off connect the electrode and work cables to the output studs. The welding process dictates the polarity of the electrode cable. These connections should be checked periodically and tightened with a 19mm wrench.

Table below lists recommended cable sizes and lengths for rated current and duty cycle. Length refers to the distance from the welder to the work and back to the welder. Cable diameters are increased for long cable lengths to reduce voltage drops.

Total Combined Length of Electrode and Work Cables	
Cable Length	Cable Size for 305 A @ 35%Duty Cycle
0-30 meters	1/0 AWG
30-46 meters	2/0 AWG
46-61 meters	3/0 AWG

Cable Installation

Install the welding cables to your machine as follows:

1. The diesel engine must be OFF to install welding cables.
2. Remove the flanged nuts from the output terminals.
3. Connect the electrode holder and work cables to the weld output terminals. The terminals are identified on the case front.
4. Tighten the flanged nuts securely.
5. Be certain that the metal piece you are welding (the "work") is properly connected to the work clamp and cable.
6. Check and tighten the connections periodically.

WARNING

- Loose connections will cause the output terminals to overheat. The terminals may eventually melt.
- Do not cross the welding cables at the output terminal connection. Keep the cables isolated and separate from one another.

Auxiliary Power

The auxiliary power capacity is 8500W Peak, 8000W continuous of 50Hz, three phase power. The auxiliary power capacity rating in watts is equivalent to volt-amperes at unity power factor. The max permissible current of the 400 VAC output is 12A. Output voltage is within $\pm 10\%$ at all loads up to the rated capacity.

Standby Power Connections

The machine is suitable for temporary, standby or emergency power using the engine manufacturer's recommended maintenance schedule.

The machine can be permanently installed as a standby power unit for 400 VAC, three phase, 12A service.

Connections must be made by a licensed electrician who can determine how the power can be adapted to the particular installation and comply with all applicable electrical codes.

- Take necessary steps to assure load is limited to the capacity of the RANGER® 305D (CE).

WARNING

- Only a licensed, certified, trained electrician should install the machine to a premises or residential electrical system. Be certain that:
- The installation complies with the National Electrical Code and all other applicable electrical codes.
- The premises is isolated and no feedback into the utility system can occur. Certain laws require the premises to be isolated before the generator is linked to the premises. Check your local requirements.

Connection of Lincoln Electric Wire Feeders

Connection of the LN-15 to the RANGER® 305D (CE)

These connections instructions apply to both the LN-15 across the Arc and Control Cable models. The LN-15 has an internal contactor and the electrode is not energized until the gun trigger is closed. When the gun trigger is closed the wire will begin to feed and the welding process is started.

- Shut the welder off.
- For electrode Positive, connect the electrode cable to the "+" terminal of the welder and work cable to the "-" terminal of the welder. For electrode Negative, connect the electrode cable "-" terminal of the welder and work cable to the "+" terminal of the welder.

Across The-Arc Model:

- Attach the single lead from the front of the LN-15 to work using the spring clip at the end of the lead. This is a control lead to supply current to the wire feeder motor; it does not carry welding current.
- Set the "WELD TERMINALS" switch to "WELD TERMINALS ON".

Control Cable Model:

- Connect Control Cable between Engine Welder and Feeder.
- Set the MODE switch to the "CV-WIRE" position.
- Set the "WELD TERMINALS" switch to "REMOTELY CONTROLLED".
- Set the "WIRE FEEDER VOLTMETER" switch to either "+" or "-" as required by the electrode polarity being used.
- Set the "ARC CONTROL" knob to "0" initially and adjust to suit.
- Set the "IDLE" switch to the "AUTO" position. 0

Connection of the LN-25 to the RANGER® 305D (CE)

WARNING

Shut off welder before making any electrical connections.

The LN-25 with or without an internal contactor may be used with the RANGER® 305D (CE). See the appropriate connection diagram.

NOTE: The LN-25 (K431) Remote Control Module and (K432) Remote Cable are not recommended for use with the RANGER 305D (CE).

- Shut the welder off.
- For electrode Positive, connect the electrode cable from the LN-25 to the "+" terminal of the welder and work cable to the "-" terminal of the welder. For electrode Negative, connect the electrode cable from the LN-25 to the "-" terminal of the welder and work cable to the "+" terminal of the welder.
- Attach the single lead from the front of the LN-25 to work using the spring clip at the end of the lead. This is a control lead to supply current to the wire feeder motor; it does not carry welding current.
- Set the MODE switch to the "CV-WIRE" position.
- Set the "WELD TERMINALS" switch to "WELD TERMINALS ON"

- Set the "ARC CONTROL" knob to "0" initially and adjust to suit.
- Set the "IDLE" switch to the "AUTO" position. When not welding, the RANGER® 305D (CE) engine will be at the low idle speed. If you are using an LN-25 with an internal contactor, the electrode is not energized until the gun trigger is closed.
- When the gun trigger is closed, the current sensing circuit will cause the RANGER 305D (CE) engine to go to the high idle speed, the wire will begin to feed and the welding process started. When welding is stopped, the engine will revert to low idle speed after approximately 12 seconds unless welding is resumed.

⚠ WARNING

If you are using an LN-25 without an internal contactor, the electrode will be energized when the RANGER® 305D (CE) is started.

Connection of the LN-742 and Cobramatic to the RANGER® 305D (CE)

- Shut the welder off.
- Connect per instructions on the appropriate connection diagram in Section below.

For Auxiliary Power

Start the engine and set the IDLER control switch to the desired operating mode. Full power is available regardless of the welding control settings providing no welding current is being drawn.

Engine Operation



Before Starting the Engine:

- Be sure the machine is on a level surface.
- Open top & side engine doors and remove the engine oil dipstick and wipe it with a clean cloth. Reinsert the dipstick and check the level on the dipstick.
- Add oil (if necessary) to bring the level up to the full mark. Do not overfill. Close engine door.
- Check radiator for proper coolant level. (Fill if necessary).
- See Engine Owner's Manual for specific oil and coolant recommendations.

Add Fuel



⚠ WARNING

DIESEL FUEL can cause fire.



- Stop engine while fueling.
- Do not smoke when fueling.
- Keep sparks and flame away from tank.
- Do not leave unattended while fueling
- Wipe up spilled fuel and allow fumes to clear before starting engine.
- Do not overfill tank, fuel expansion may cause overflow.

DIESEL FUEL ONLY.

- Remove the fuel tank cap.
- Fill the tank approximately 4 inches (100mm) from the top of the filler neck to allow for fuel expansion (observe the fuel gauge while filling). **DO NOT FILL THE TANK TO THE POINT OF OVERFLOW.**
- Replace the fuel cap and tighten securely.
- See Engine Owner's Manual for specific fuel recommendations.

Break-in Period

Any engine will use a small amount of oil during its "break-in" period. For the diesel engine on the RANGER® 305D (CE), break-in is about 50 running hours.

Check the oil every four hours during break-in. Change the oil after the first 50 hours of operation, every 100 hours thereafter. Change the oil filter at the second oil change.

⚠ WARNING

During break-in, subject the RANGER® 305D (CE) to moderate loads. Avoid long periods running at idle. Before stopping the engine, remove all loads and allow the engine to cool several minutes.

**Controls and Operational Features
Welding Controls**

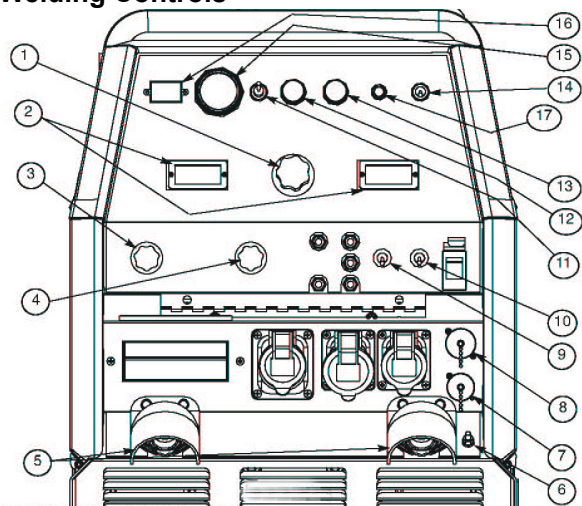

Figure 1

1. **Output Control:** The OUTPUT dial is used to preset the output voltage or current as displayed on the digital meters for the four welding modes. When in the CC-STICK, or CV-WIRE modes and when a remote control is connected to the 6-Pin or 14-Pin Connector, the auto-sensing circuit automatically switches the OUTPUT CONTROL from control at the welder to the remote control.

When in the DOWNHILL PIPE mode and when a REMOTE CONTROL is connected to the 6-Pin or 14-Pin Connector, the OUTPUT CONTROL is used to set the maximum current range of the OUTPUT CONTROL of the REMOTE.

Example:

When the OUTPUT CONTROL on the welder is set to 200 amps the current range on the REMOTE CONTROL will be 40-200 amps rather than the full 40-300 amps. Any current range that is less than the full range provides finer current resolution for more fine tuning of the output.

In the CV-WIRE mode, if the wire feeder has voltage control capability, when the control cable is connected to the 14-Pin Connector, the auto-sensing circuit automatically makes OUTPUT CONTROL inactive and the wire feeder voltage control active.

When in the TOUCH START TIG mode and when a Amptrol is connected to the 6-Pin Connector, the OUTPUT control is used to set the maximum current range of the CURRENT CONTROL of the Amptrol.

2. **Digital Output Meters:** The digital meters allow the output voltage (CVWIRE mode) or current (CC-STICK, PIPE and TIG modes) to be set prior to welding using the OUTPUT control dial. During welding, the meter display the actual output voltage (V) and current (A). A memory feature holds the display of both meters on for seven seconds after welding is stopped. This allows the operator to read the actual current and voltage just prior to when welding was ceased. While the display is being held the left-most decimal point in each display will be flashing. The accuracy of the meters is +/- 3%.
3. **Weld Mode Selector Switch:** (Provides four selectable welding modes)
 - CV-WIRE
 - DOWNHILL PIPE
 - CC-STICK
 - TOUCH START TIG
4. **Arc Control:** The ARC CONTROL dial is active in the CV-WIRE, CC-STICK and DOWNHILL PIPE modes, and has different functions in these modes. This control is not active in the TIG mode.
 - **CC-STICK mode:** In this mode, the ARC CONTROL dial sets the short circuit current (arc-force) during stick welding to adjust for a soft or crisp arc. Increasing the dial from -10 (soft) to +10 (crisp) increases the short circuit current and prevents sticking of the electrode to the plate while welding. This can also increase spatter. It is recommended that the ARC CONTROL be set to the minimum number without electrode sticking. Start with a setting at 0.
 - **DOWNHILL PIPE mode:** In this mode, the ARC CONTROL dial sets the short circuit current (arc-force) during stick welding to adjust for a soft or a more forceful digging arc (crisp). Increasing the number from -10 (soft) to +10 (crisp) increases the short circuit current which results in a more forceful digging arc. Typically a forceful digging arc is preferred for root and hot passes. A softer arc is preferred for fill and cap passes where weld puddle control and deposition ("stacking" of iron) are key to fast travel speeds. It is recommended that the ARC CONTROL be set initially at 0.



- **CV-WIRE mode:** In this mode, turning the ARC CONTROL clock wise from -10 (soft) to +10 (crisp) changes the arc from soft and washed-in to crisp and narrow. It acts as an inductance/pinch control. The proper setting depends on the procedure and operator preference. Start with a setting of 0.

5. **Weld Output Terminals with Flange Nut:** Provides a connection point for the electrode and work cables.
6. **Ground Stud** : Provides a connection point for connecting the machine case to earth ground.
7. **14-pin Connector:** For attaching wire feeder control cables to the RANGER® 305D (CE). Includes contactor closure circuit, auto-sensing remote control circuit, and 42V power. The remote control circuit operates the same as the 6 Pin connector. Note: The 14-pin connector does not include 120V.
8. **6-pin Connector:** For attaching optional remote control equipment. Includes auto-sensing remote control circuit.
9. **Weld Terminals Switch:** In the WELD TERMINALS ON position, the output is electrically hot all the time. In the REMOTELY CONTROLLED position, the output is controlled by a wire feeder or amptrol device, and is electrically off until a remote switch is depressed.
10. **Wire Feeder Voltmeter Switch:** Matches the polarity of the wire feeder voltmeter to the polarity of the electrode.

Engine Controls



Figure 2

11. **Run/Stop Switch:** RUN position energizes the engine prior to starting. STOP position stops the engine. The oil pressure interlock switch prevents battery drain if the switch is left in the RUN position and the engine is not operating.
12. **Glow Plug Push Button:**  When pushed activates the glow plugs. Glow plug should not be activated for more than 20 seconds continuously.
13. **Start Push Button:**  Energizes the starter motor to crank engine.

14. **Idler Switch:** Has two positions as follows:
- 1) In the HIGH position, the engine runs at the high idle speed controlled by the engine governor.
 - 2) In the AUTO position, the idler operates as follows:
 - When switched from HIGH to AUTO or after starting the engine, the engine will operate at full speed for approximately 12 seconds and then go to low idle speed.
 - When the electrode touches the work or power drawn for lights or tools (approximately 100W minimum), the engine accelerates and operates at full speed.
 - When welding ceases or the AC power load is turned off, a fixed time delay of approximately 12 seconds starts. If the welding or AC power load is not restarted before the end of the time delay, the idler reduces the engine speed to low idle speed.
 - The engine will automatically return to high idle speed when there is welding load or AC power load reapplied.
15. **Electric Fuel Gauge:** Provides accurate, reliable indication of how much fuel is in the tank.
16. **Engine Hour Meter:** Displays the total time that the engine has been running. This meter is useful for scheduling prescribed maintenance.
17. **Engine Protection Light:** A warning indicator light for Low Oil Pressure and/or Coolant Over Temperature. The light is off when the systems are functioning properly. The light turns on when the RUN-STOP switch is in the "ON" position prior to starting the engine. If the Engine Protection or Battery Charging Lights do "not" turn off shortly after starting the engine shut off the engine immediately and determine the cause.

Starting the Engine

1. Remove all plugs connected to the AC power receptacles.
2. Set IDLER switch to AUTO. 
3. Set the RUN/STOP switch to RUN.
4. Press Glow Plug Button and hold 5 to 10 seconds.
5. Press and hold both the "Glow Plug" Button and START button together until the engine starts or for up to 10 seconds.
6. Release the engine START button immediately when the engine starts.
7. Release the glow plug button after the Engine Protection Light turns off or after an additional 5 seconds maximum.
8. The engine will run at high idle speed for approximately 12 seconds and then drop to low idle speed. Allow the engine to warm up at low idle for several minutes before applying a load and/or switching to high idle. Allow a longer warm up time in cold weather.

Note: If the unit fails to start repeat step 4 through step 7 after waiting 30 seconds

WARNING

- Do not allow the starter motor to run continuously for more than 20 seconds.
- Do not push the START button while the engine is running because this can damage the ring gear and/or the starter motor.
- If the Engine Protection or Battery Charging Lights do "not" turn off shortly after starting the engine shut off the engine immediately and determine the cause.

Note: When starting a RANGER® 305D (CE) for the first time, or after an extended period of time of not operating, it will take longer than normal because the fuel pump has to fill the fuel system.

Stopping the Engine

Remove all welding and auxiliary power loads and allow the engine to run at low idle speed for a few minutes to cool the engine.

STOP the engine by placing the RUN-STOP switch in the STOP position.

Note: A fuel shut off valve is located on the fuel pre-filter. Turn on Fuel shut-off valve on the fuel pre-filter.

TYPICAL RANGER® 305D (CE) FUEL CONSUMPTION		
	Kubota D722 Liters/Hr	Running time for 45 Liters/hours
Low Idle - No Load 2200 R.P.M.	.92	49.38
High Idle - No Load 3100 R.P.M.	1.62	28.07
DC Weld Output 250A @ 30V	3.42	13.30
DC Weld Output 225A @ 25V	2.92	15.55
8000 Watts, 3 Phase	3.35	13.54
5000 Watts, 3 Phase	2.65	17.12
3000 Watts, 3 Phase	2.19	20.78

Welder Operation

Duty Cycle

Duty Cycle is the percentage of time the load is being applied in a 10-minute period. For example a 60% duty cycle, represents 6 minutes of load and 4 minutes of no load in a 10-minute period.

The RANGER® 305D (CE) can be used with a broad range of DC stick electrodes. The MODE switch provides two stick welding settings as follows:

CONSTANT CURRENT (CC-STICK) Welding

The CC-STICK position of the MODE switch is designed for horizontal and vertical-up welding with all types of electrodes, especially low hydrogen.

The OUTPUT CONTROL dial adjusts the full output range for stick welding.

The ARC CONTROL dial sets the short circuit current (arc force) during stick welding to adjust for a soft or crisp arc. Increasing the dial from -10 (soft) to +10 (crisp) increases the short circuit current and prevents sticking of the electrode to the plate while welding. This can also increase spatter. It is recommended that the ARC CONTROL be set to the minimum number without electrode sticking. Start with a setting at 0.

DOWNHILL PIPE (STICK) Welding

The DOWNHILL PIPE position of the MODE switch is a slope controlled setting intended for "out-of-position" and "down hill" pipe welding where the operator would like to control the current level by changing the arc length. The OUTPUT CONTROL dial adjusts the full output range for stick welding. The ARC CONTROL dial sets the short circuit current (arc-force) during stick welding to adjust for a soft or a more forceful digging arc (crisp). Increasing the number from -10 (soft) to +10 (crisp) increases the short circuit current which results in a more forceful digging arc. Typically a forceful digging arc is preferred for root and hot passes. A softer arc is preferred for fill and cap passes where weld puddle control and deposition ("stacking" of iron) are key to fast travel speeds. It is recommended that the ARC CONTROL be set initially at 0.

TIG WELDING

The TOUCH START TIG setting of the MODE switch is for DC TIG (Tungsten Inert Gas) welding. To initiate a weld, the OUTPUT CONTROL dial is first set to the desired current and the tungsten is touched to the work. During the time the tungsten is touching the work there is very little voltage or current and, in general, no tungsten contamination. Then, the tungsten is gently lifted off the work in a rocking motion, which establishes the arc.

To stop the arc, simply lift the TIG torch away from the work piece. When the arc voltage reaches approximately 30 volts, the arc will go out and the machine will automatically reset to the touch start current level. The tungsten may then be retouched to the work piece to restrike the arc. The arc may also be started and stopped with an Amptrol or Arc Start Switch. See the following paragraphs.

TYPICAL CURRENT RANGES ⁽¹⁾ FOR TUNGSTEN ELECTRODES ⁽²⁾							
Tungsten Electrode Diameter (mm)	DCEN (-)	DCEP (+)	Approximate Argon Gas Flow Flow Rate C.F.H. (l/min)				TIG TORCH Nozzle Size (4), (5)
	1%, 2% Thoriated Tungsten	1%, 2% Thoriated Tungsten	Aluminum		Stainless Steel		
.25	2-15	(3)	3-8	(2-4)	3-8	(2-4)	#4, #5, #6
.50	5-20	(3)	5-10	(3-5)	5-10	(3-5)	
1.0	15-80	(3)	5-10	(3-5)	5-10	(3-5)	
1.6	70-150	10-20	5-10	(3-5)	9-13	(4-6)	#5, #6
2.4	150-250	15-30	13-17	(6-8)	11-15	(5-7)	#6, #7, #8
3.2	250-400	25-40	15-23	(7-11)	11-15	(5-7)	
4.0	400-500	40-55	21-25	(10-12)	13-17	(6-8)	#8, #10
4.8	500-750	55-80	23-27	(11-13)	18-22	(8-10)	
6.4	750-1000	80-125	28-32	(13-15)	23-27	(11-13)	

(1) When used with argon gas. The current ranges shown must be reduced when using argon/helium or pure helium shielding gases.

(2) Tungsten electrodes are classified as follows by the American Welding Society (AWS):

- Pure EWP
- 1%Thoriated EWTh-1
- 2%Thoriated EWTh-2

Though not yet recognized by the AWS, Ceriated Tungsten is now widely accepted as a substitute for 2% Thoriated Tungsten in AC and DC applications.

(3) DCEP is not commonly used in these sizes.

(4) TIG torch nozzle "sizes" are in multiples of 1/16ths of an inch:

- # 4 = 6 mm
- # 5 = 8 mm
- # 6 = 10 mm
- # 7 = 11 mm
- # 8 = 12.5 mm
- #10 = 16 mm

(5) TIG torch nozzles are typically made from alumina ceramic. Special applications may require lava nozzles, which are less prone to breakage, but cannot withstand high temperatures and high duty cycles.

When in the TOUCH START TIG mode and when an Amptrol is connected to the 6-pin Connector the OUTPUT dial is used to set the maximum current range of the CURRENT CONTROL of the Amptrol.

The ARC CONTROL is not active in the TIG mode.

The RANGER® 305D (CE) can be used in a wide variety of DC TIG welding applications. In general the "Touch Start" feature allows contamination free starting without the use of a Hi frequency unit. If desired, the K930-2 TIG Module can be used with the RANGER® 305D (CE). The settings are for reference.

RANGER® 305D (CE) settings when using the K930-2 TIG Module with an Amptrol or Arc Start Switch:

- Set the MODE Switch to the TOUCH START TIG setting.
- Set the "IDLER" Switch to the "AUTO" position.
- Set the "WELDING TERMINALS" switch to the "REMOTELY CONTROLLED" position. This will keep the "Solid State" contactor open and provide a "cold" electrode until the Amptrol or Arc Start Switch is pressed.

When using the TIG Module, the OUTPUT control on the RANGER 305D (CE) is used to set the maximum range of the CURRENT CONTROL on the TIG module or an Amptrol if connected to the TIG Module. (See table above).

Wire Welding-CV

Connect a wire feeder to the Ranger 305D (CE) according to the instructions in INSTALLATION INSTRUCTIONS Section.

The RANGER® 305D (CE) in the CV-WIRE mode, permits it to be used with a broad range of flux cored wire (Innershield and Outershield) electrodes and solid wires for MIG welding (gas metal arc welding). Welding can be finely tuned using the ARC CONTROL. Turning the ARC CONTROL clockwise from -10 (soft) to +10 (crisp) changes the arc from soft and washed-in to crisp and narrow. It acts as an inductance/pinch control. The proper setting depends on the procedure and operator preference. Start with the dial set at 0.

For any electrodes the procedures should be kept within the rating of the machine. For additional electrode information see www.Lincolnelectric.com or the appropriate Lincoln publication.

Arc Gouging

The RANGER® 305D (CE) can be used for limited arc gouging. For optimal performance, set the MODE switch to CC-STICK and the ARC CONTROL to +10.

Set the OUTPUT CONTROL knob to adjust output current to the desired level for the gouging electrode being used according to the ratings in the following table:

Carbon Diameter (mm)	Current Range (DC, electrode positive) (A)
3.2	60 - 90
4.0	90 - 150
4.75	200 - 250

Auxiliary Power

Start the engine and set the IDLER control switch to the desired operating mode. Full power is available regardless of the welding control settings providing no welding current is being drawn.

Simultaneous Welding and Auxiliary Power Loads

While welding, the amount of 3-phase Auxiliary power available is reduced. (See Table below).

Welding Output (A)	Permissible Power(W) (Unity Power Factor)	Permissible Aux Power @400V, 3 phase (A)
0	8000	12
50	6500	9
100	5000	7
150	3500	5
200	2000	3
250	0	0

Accessories

Field Installed Options / Accessories

K704 Accessory Set - Includes (10m) 35 ft. of electrode cable and (9m) 30 ft. of work cable, head shield, work clamp electrode holder. Cables are rated at 400A, 100% duty cycle.

K857 7.6m or K857-1 30.4m Remote Control - Portable control provides same dial range as the output control on the welder. Has a convenient 6-pin plug for easy connection to the welder.

Maintenance

WARNING

- Have qualified personnel do all maintenance and troubleshooting work.
- Turn the engine off before working inside the machine or servicing the engine.
- Remove guards only when necessary to perform maintenance and replace them when the maintenance requiring their removal is complete. If guards are missing from the machine, obtain replacements from a Lincoln Distributor. (See Operating Manual Parts List.)
- Read the Safety Precautions in the front of this manual and in the Engine Owner's Manual before working on this machine.
- Keep all equipment safety guards, covers, and devices in position and in good repair. Keep hands, hair, clothing, and tools away from the gears, fans, and all other moving parts when starting, operating, or repairing the equipment.

Routine Maintenance

At the end of each day's use, refill the fuel tank to minimize moisture condensation in the tank. Running out of fuel tends to draw dirt into the fuel system. Also, check the crankcase oil level and add oil if indicated.

Engine Maintenance Components Kubota D722 Diesel Engine

Item	Make and Part Number
Oil Filter	Kubota 70000-15241
Air Filter Element	Donaldson P822686
Fuel Filter Element	Kubota 15231-43560
Battery	Kubota group 58, 550 CCA
Belt	Kubota 15881-97011
Glow Plugs	Kubota 16851-65512
Inline Fuel Filter	Kubota 12581-43012

Frequency	Maintenance Required
Daily or before starting engine	Fill fuel tank.
	Check oil level.
	Check coolant level.
	Check air cleaner element and housing for dirty, loose or damaged parts.
	Check air intake hose for cracks or loose connections.
	Check air intake/exhaust areas & radiator for dirt. clean as necessary.
	Check alternator belt tension and wear.

Service Intervals

Observe the following for service and maintenance. The lubricating oil change intervals listed in the table below are for Classes CF,CE and CD lubricating oils of API classification with a low sulfur fuel in use. If the CF-4 or CG-4 lubricating oil is used with a high-sulfur fuel, change the lubricating oil at shorter intervals than recommended in the table below depending on the operating condition.

Intervals	Items	
Every 50 h	Check of fuel lines and clamp bands.	
Every 75 h	Change of engine oil	•
Every 100 h	Inspect/Clean air cleaner element and Vacuator™ valve.	*1
	Cleaning of fuel filter.	
	Check the battery electrolyte level.	
	Check the fan belt tightness.	
Every 150 h	Check the radiator and hose clamps.	•
	Replacement of oil filter cartridge.	
	Check the intake air lines.	
Every 200 h	Replacement of air filter element.	*1 *2
Every 400 h	Replacement of fuel filter element.	
Every 500 h	Removal of sediment in fuel tank.	
	Cleaning of water jacket (radiator interior).	
	Replacement of fan belt.	
Every 1 or 2 months	Recharging of Battery.	
Every 800 h	Check of valve clearance.	*3
Every 1500 h	Check the fuel injection nozzle injection pressure.	*3
Every 3000 h	Check of injection pump.	*3
	Check of fuel injector timer.	*3
Every 2 years	Replacement of battery	
	Replacement of radiator hoses and clamp band.	
	Replacement of fuel pipes and clamps.	
	Change the radiator coolant.(L.L.C.)	*4
	Replacement of intake air line.	

Important

- These jobs should be done after the first 50 hours of operation.
- *1 Air cleaner should be inspected/cleaned more often in dusty conditions than the normal conditions.
- *2 Follow Service Instructions and Installation Tips for air cleaner in Section D.
- *3 Consult your local KUBOTA Dealer for this service.
- *4 Replace only if necessary.

Please see Engine Owners Manual for Warranty Statement in detail.

Engine Oil Change



Drain the engine oil while the engine is warm to assure rapid and complete draining. It is recommended that each time the oil is changed the oil filter be changed as well.

- Be sure the unit is off. Disconnect the negative battery cable to ensure safety.
- Locate oil drain hose and valve in bottom of base and pull through the hole in the battery access panel on the welder.
- Remove the cap from the drain valve. Push valve in and twist counter clockwise. Pull to open and drain the oil into a suitable container for disposal.
- Close the drain valve by pushing in and twisting clockwise. Replace the cap.
- Re-fill the crankcase to the upper limit mark on the dipstick with the recommended oil (see engine operation manual OR engine service items decal OR below). Replace and tighten the oil filler cap securely.
- Push oil drain hose and valve back into unit, reconnect negative battery cable, and close doors and engine top cover before restarting unit. Wash your hands with soap and water after handling used motor oil. Please dispose of used motor oil in a manner that is compatible with the environment. We suggest you take it in a sealed container to your local service station or recycling center for reclamation. DO NOT throw it in the trash; pour it on the ground or down a drain.

Engine Oil Refill Capacities

Without oil filter replacement: 3.2 liter

With oil filter replacement: 3.2 liter

Use motor oil designed for diesel engines that meets requirements for API service classification CC/CD/CE/CF/CF-4/CG-4 or CH-4. ACEA E1/E2/E3. Always check the API service label on the oil container to be sure it includes the letters indicated. (**Note:** An S-grade oil must not be used in a diesel engine or damage may result. It is permissible to use an oil that meets S and C grade service classifications.) SAE 10W30 is recommended for general, all temperature use, -15C to 40C (5F to 104F). See engine owner's manual for more specific information on oil viscosity recommendations.

Oil Filter Change

- Drain the oil
- Remove the oil filter with an oil filter wrench and drain the oil into a suitable container. Discard the used filter. **Note:** Care should be taken during filter removal to not disrupt or damage in any way the fuel lines.
- Clean the filter mounting base and coat the gasket of the new filter with clean engine oil.
- Screw the new filter on by hand until the gasket contacts the mounting base. Using an oil filter wrench, tighten the filter an additional 1/2 to 7/8 of a turn.

- Refill the crankcase with the specified amount of the recommended engine oil. Reinstall the oil filler cap and tighten securely.
- Start the engine and check for oil filter leaks.
- Stop the engine and check the oil level. If necessary, add oil to the upper limit mark on the dipstick.

 **WARNING**

Never use gasoline or low flash point solvents for cleaning the air cleaner element. A fire or explosion could result.

 **WARNING**

Never run the engine without the air cleaner. Rapid engine wear will result from contaminants, such as dust and dirt being drawn into the engine.

Air Cleaner

The diesel engine is equipped with a dry type air filter. Never apply oil to it. Service the air cleaner as follows:

- Replace the element at least every 200 hours of operation and sooner under dusty conditions.

Cooling System

 **WARNING**

HOT COOLANT can burn skin.

- Do not remove cap if radiator is hot.



Check the coolant level by observing the level in the radiator and recovery bottle. Add 50/50 antifreeze/water solution if the level is close to or below the "LOW" mark. do not fill above the "FULL" mark. Remove radiator cap and add coolant to radiator. Fill up to the top of the tube in the radiator filler neck which includes a connecting hose coming from the thermostat housing.

To drain the coolant, open the valve of the radiator. Open the radiator cap to allow complete drainage. (Tighten the valve and refill with a 50/50 antifreeze/water solution.) Use an automotive grade (low silicate) ethylene glycol antifreeze. The cooling system capacity is 3.6l. Squeeze upper and lower radiator hoses while filling to bleed air from system coolant. Replace and tighten the radiator cap.

 **WARNING**

Always premix the antifreeze and clean tap water before adding to the radiator. It is very important that a precise 50/50 solution be used with this engine year round. This gives proper cooling during hot weather and freezing protection to -37° C.

Cooling solution exceeding 50% ethylene glycol can result in engine overheating and damage to the engine. Coolant solution must be premixed before adding to radiator.

Periodically remove the dirt from the radiator fins.

Periodically check the fan belt and radiator hoses. Replace if signs of deterioration are found.

Tightening the Fan Belt

If the fan belt is loose, the engine can overheat and the battery lose its charge. Check tightness by pressing on the belt midway between the pulleys. It should deflect about 6mm under a load of 9 Kg.

Fuel



At the end of each day's use, refill the fuel tank to minimize moisture condensation and dirt contamination in the fuel line. Do not overfill; leave room for the fuel to expand.

Use only fresh, No. 2 grade DIESEL fuel. Do not use kerosene.

See the Engine Operator's Manual for instructions on replacing the fuel filter.

Bleeding the Fuel System

You may need to bleed air from the fuel system if the fuel filter or fuel lines have been detached, the fuel tank has been ran empty or after periods of long storage. It is recommended that the fuel shutoff valve be closed during periods of non-use.

The Kubota D722 engine supplied with this welder is equipped with an automatic bleeding mechanism that helps purge the air from the mechanical fuel pump system. It is generally not necessary to open a vent screw or fuel line fitting to bleed the fuel system. Operate the priming lever on the pump to assist starting after extended periods of non-use or out of fuel conditions.

 **WARNING**

To avoid personal injury, do not bleed a hot engine. This could cause fuel to spill onto a hot exhaust manifold, creating a danger of fire.

Bleed the fuel system as follows:

- Fill the fuel tank with fuel.
- Open the fuel shut off valve (vertical position of handle) on the Fuel Filter.
- Crank the engine by pressing the start button for 45 seconds.
- Check to see that fuel is flowing through both fuel filters.
- Follow the normal STARTING procedures.

Fuel Filter

- Check the fuel filter and fuel pre-filter for water accumulation or sediment.
- Replace the fuel filter if it is found with excessive water accumulation or sediment. Empty fuel pre-filter.

 **WARNING**

OVERSPEED IS HAZARDOUS. The maximum allowable high idle speed for this machine is 3150 RPM, no load. Do NOT tamper with governor components or setting or make any other adjustments to increase the maximum speed. Severe personal injury and damage to the machine can result if operated at speeds above maximum.

Engine Adjustment

Adjustments to the engine are to be made only by a Lincoln Service Center or an authorized Field Service Shop.

Battery Maintenance

To access the battery, disconnect the Negative and then Positive battery cables. Remove the 4 screws from the battery door using a screwdriver or a 10mm socket. Remove the 2 nuts from the battery bracket using a 11mm wrench or socket. Slide the battery out and remove from welder

WARNING

GASES FROM BATTERY can explode.

Keep sparks, flame and cigarettes away from battery.



To prevent EXPLOSION when:

- **INSTALLING A NEW BATTERY** — disconnect negative cable from old battery first and connect to new battery last.
- **CONNECTING A BATTERY CHARGER** - remove battery from welder by disconnecting negative cable first, then positive cable and battery clamp. When reinstalling, connect negative cable last. Keep well ventilated.
- **USING A BOOSTER** — connect positive lead to battery first then connect negative lead to negative battery lead at engine foot.
- **BATTERY ACID** can burn eyes and skin- wear gloves and eye protection and be careful when working near battery.



- Follow instructions printed on battery.

Cleaning the Battery

Keep the battery clean by wiping it with a damp cloth when dirty. If the terminals appear corroded, disconnect the battery cables and wash the terminals with an ammonia solution or a solution of 113g of baking soda and 0.9461L of water. Be sure the battery vent plugs (if equipped) are tight so that none of the solution enters the cells. After cleaning, flush the outside of the battery, the battery compartment, and surrounding areas with clear water. Coat the battery terminals lightly with petroleum jelly or a non-conductive grease to retard corrosion. Keep the battery clean and dry. Moisture accumulation on the battery can lead to more rapid discharge and early battery failure.

Checking the Electrolyte Level

If battery cells are low, fill them to the neck of the filler hole with distilled water and recharge. If one cell is low, check for leaks.

Charging the Battery

When you charge, jump, replace, or otherwise connect battery cables to the battery, be sure the polarity is correct. Improper polarity can damage the charging circuit. The RANGER® 305D (CE) positive (+) battery terminal has a red terminal cover.

If you need to charge the battery with an external charger, disconnect the negative cable first, then the positive cable before you attach the charger leads. After the battery is charged, reconnect the positive battery

cable first and the negative cable last. Failure to do so can result in damage to the internal charger components. Follow the instructions of the battery charger manufacturer for proper charger settings and charging time.

Servicing Spark Arrestor

Clean every 100 hours or twice a year, whichever occurs first.

- Stop engine and allow to cool.
- Loosen clamp and remove spark arrestor from machine.
- Remove lock nut on top of spark arrestor housing and lift off cap.
- Separate plates and clean with a wire brush if necessary.
- Inspect plates and housing for holes or cracks. Replace if damaged.
- Reassemble and reinstall on to muffler outlet pipe.

WARNING

MUFFLER MAY BE HOT

Welder / Generator Maintenance

Storage: Store the RANGER® 305D (CE) in clean, dry protected areas.

Cleaning: Blow out the generator and controls periodically with low pressure air. Do this at least once a week in particularly dirty areas.

Brush Removal and Replacement: It's normal for the brushes and slip rings to wear and darken slightly. Inspect the brushes when a generator overhaul is necessary.

WARNING

Do not attempt to polish slip rings while the engine is running.

WARNING

Service and Repair should only be performed by Lincoln Electric Factory Trained Personnel. Unauthorized repairs performed on this equipment may result in danger to the technician and machine operator and will invalidate your factory warranty. For your safety and to avoid Electrical Shock, please observe all safety notes and precautions.

Customer Assistance Policy

The business of The Lincoln Electric Company is manufacturing and selling high quality welding equipment, consumables, and cutting equipment. Our challenge is to meet the needs of our customers and to exceed their expectations. On occasion, purchasers may ask Lincoln Electric for advice or information about their use of our products. We respond to our customers based on the best information in our possession at that time. Lincoln Electric is not in a position to warrant or guarantee such advice, and assumes no liability, with respect to such information or advice. We expressly disclaim any warranty of any kind, including any warranty of fitness for any customer's particular purpose, with respect to such information or advice. As a matter of practical consideration, we also cannot assume any responsibility for updating or correcting any such information or advice once it has been given, nor does the provision of information or advice create, expand or alter any warranty with respect to the sale of our products

Lincoln Electric is a responsive manufacturer, but the selection and use of specific products sold by Lincoln Electric is solely within the control of, and remains the sole responsibility of the customer. Many variables beyond the control of Lincoln Electric affect the results obtained in applying these types of fabrication methods and service requirements.

Subject to Change – This information is accurate to the best of our knowledge at the time of printing. Please refer to www.lincolnelectric.com for any updated information.

Diagrams

Engine Welders/LN-25 across the Arc Connection Diagram with Optional K857 Remote Control

⚠ WARNING

- Do not operate with panels open.
- Disconnect NEGATIVE (-) Battery lead before servicing.
- Do not touch electrically live parts.



⚠ WARNING

- Keep guards in place
- Keep away from moving parts.
- Only qualified personnel should install, use or service this equipment

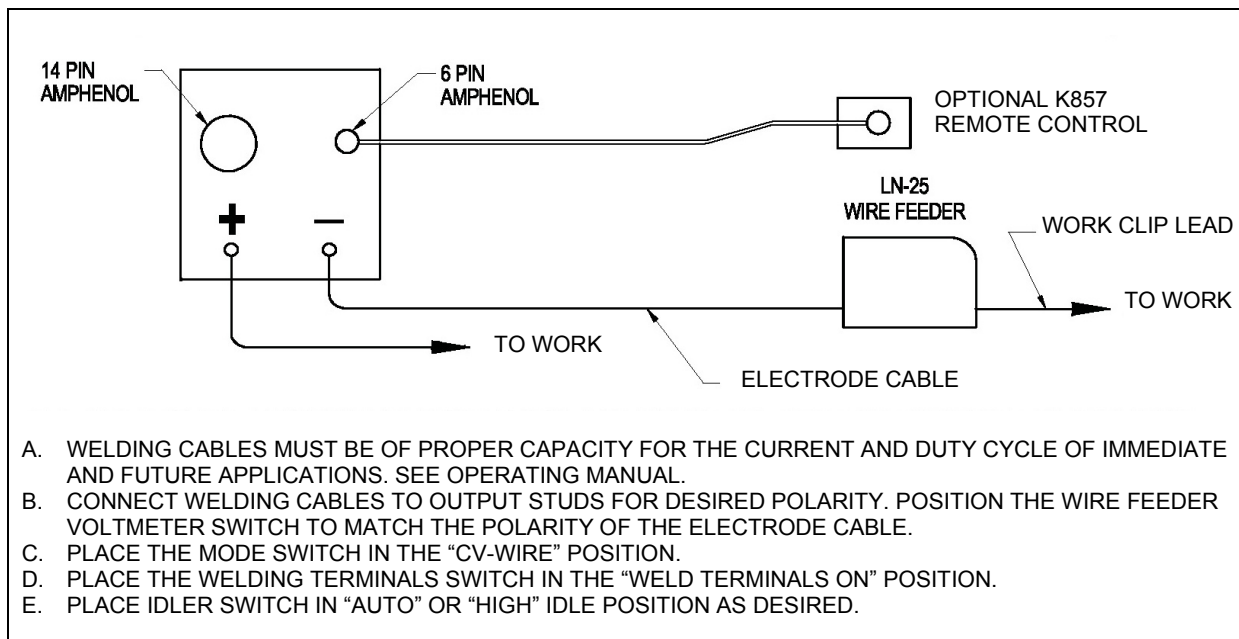

S24787-1

Engine Welders/LN-25 across the Arc Connection Diagram with Optional K444-1 Remote Control

⚠ WARNING

- Do not operate with panels open.
- Disconnect NEGATIVE (-) Battery lead before servicing.
- Do not touch electrically live parts.



⚠ WARNING

- Keep guards in place
- Keep away from moving parts.
- Only qualified personnel should install, use or service this equipment

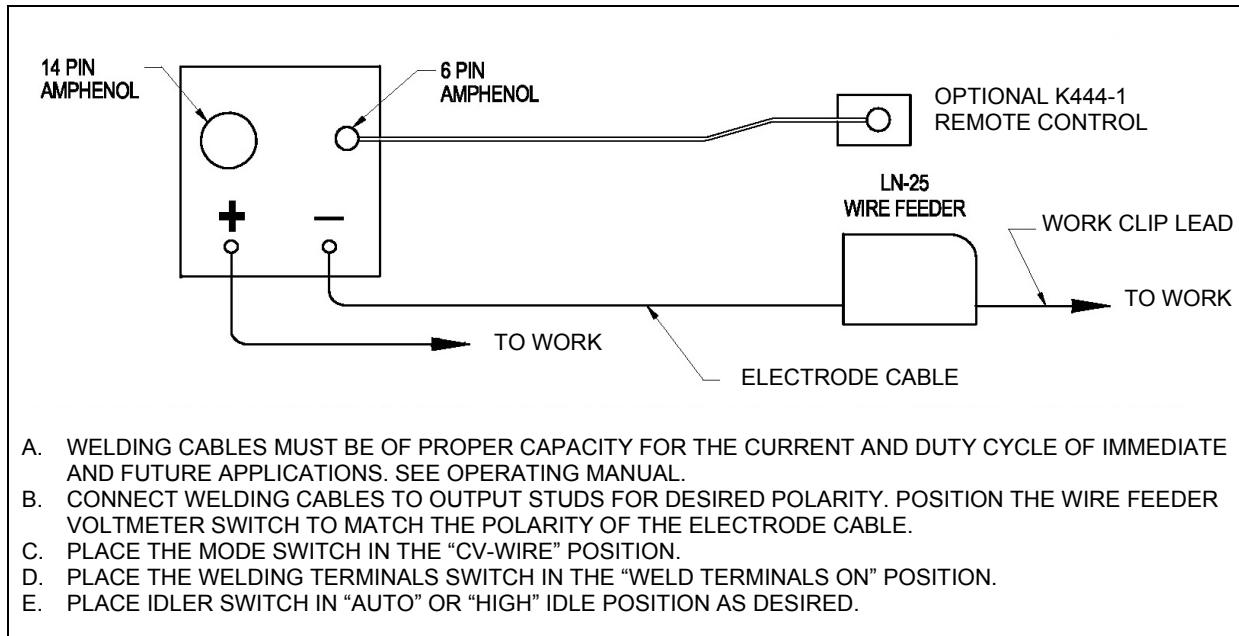

S24787-2

Engine Welders/LN-742 Connection Diagram

WARNING

- Do not operate with panels open.
- Disconnect NEGATIVE (-) Battery lead before servicing.
- Do not touch electrically live parts.



WARNING

- Keep guards in place
- Keep away from moving parts.
- Only qualified personnel should install, use or service this equipment

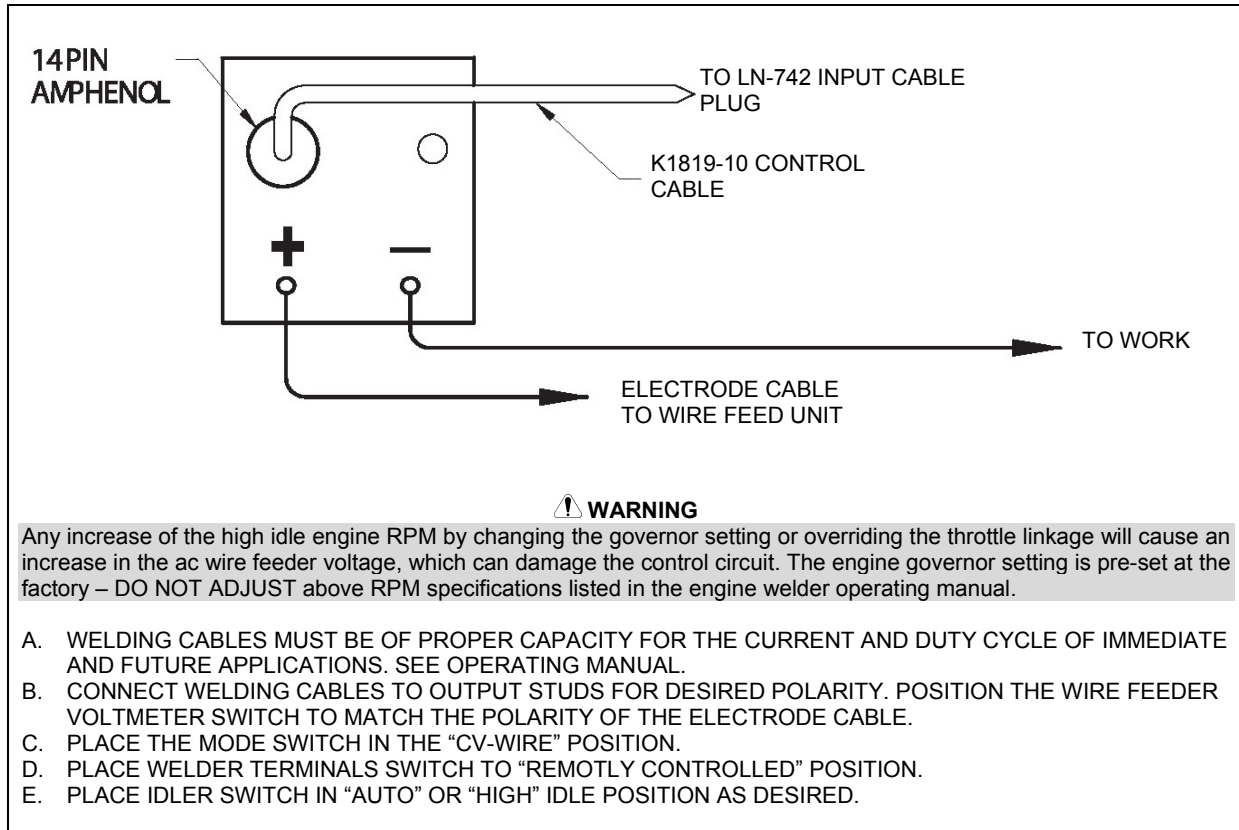

S24787-13

Engine Welders/K930 Tig Module Connection Diagram

⚠ WARNING

- Do not operate with panels open.
- Disconnect NEGATIVE (-) Battery lead before servicing.
- Do not touch electrically live parts.



⚠ WARNING

- Keep guards in place
- Keep away from moving parts.
- Only qualified personnel should install, use or service this equipment

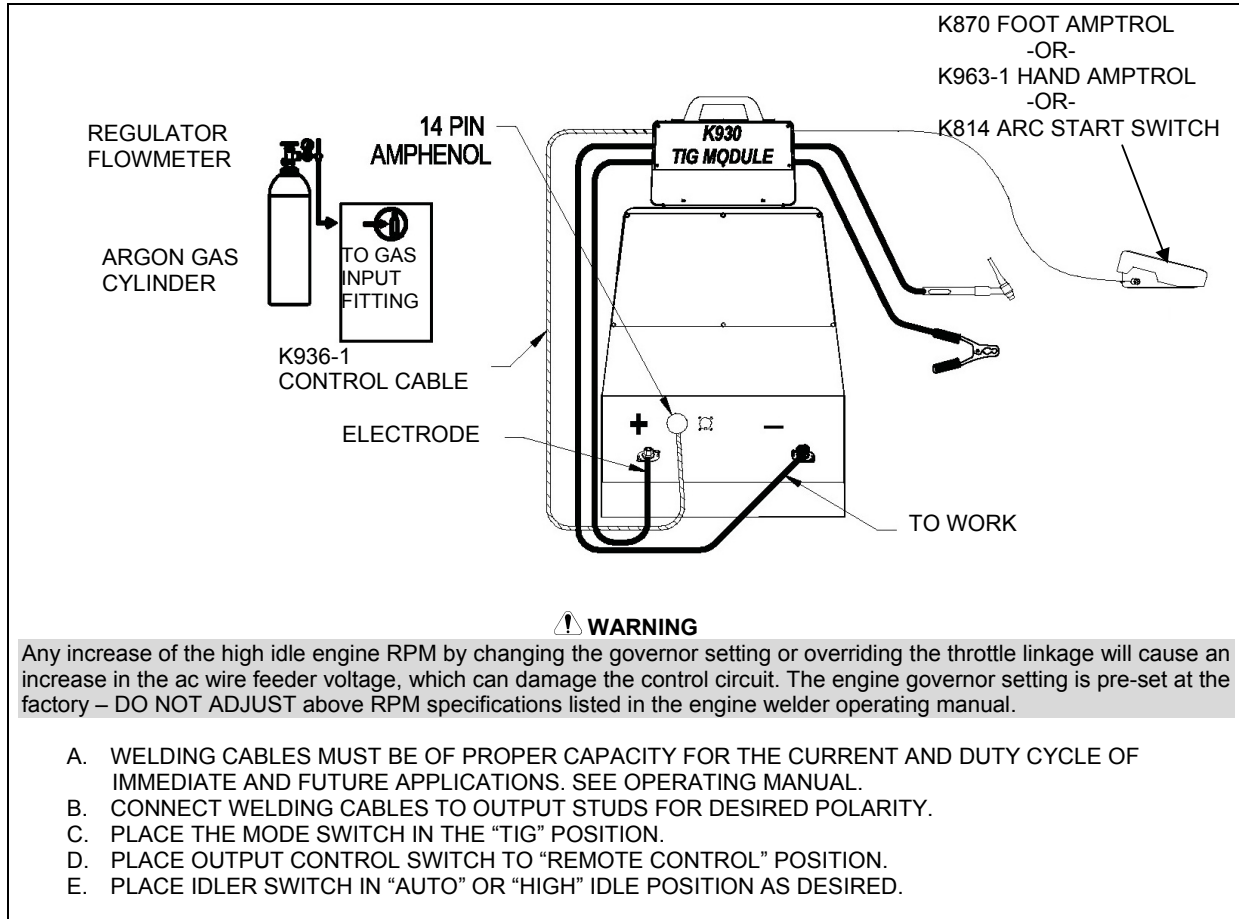

S24787-9

Engine Welders/K1587-1 Cobramatic Connection Diagram

WARNING

- Do not operate with panels open.
- Disconnect NEGATIVE (-) Battery lead before servicing.
- Do not touch electrically live parts.



WARNING

- Keep guards in place
- Keep away from moving parts.
- Only qualified personnel should install, use or service this equipment

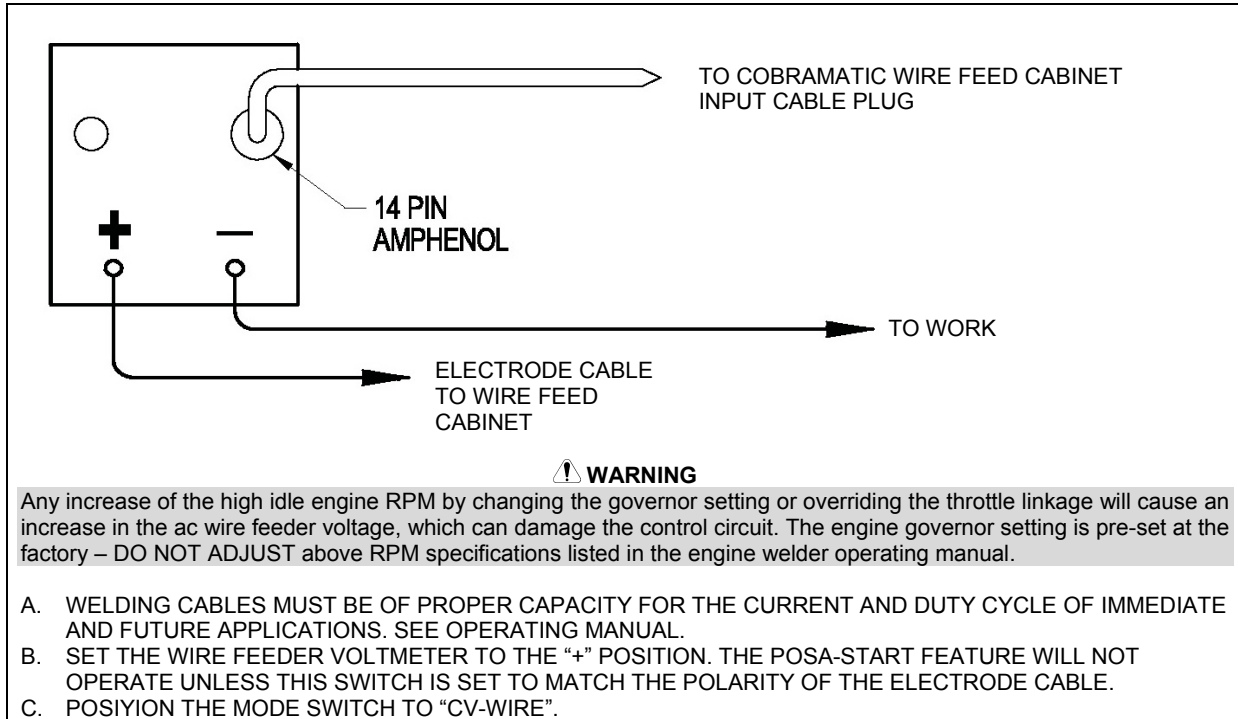

S24787-10

WEEE

07/06

English



Do not dispose of electrical equipment together with normal waste!
In observance of European Directive 2012/19/EC on Waste Electrical and Electronic Equipment (WEEE) and its implementation in accordance with national law, electrical equipment that has reached the end of its life must be collected separately and returned to an environmentally compatible recycling facility. As the owner of the equipment, you should get information on approved collection systems from our local representative.

By applying this European Directive you will protect the environment and human health!

Spare Parts

12/05

For Spare Parts references visit the Web page: <https://www.lincolnelectric.com/LEExtranet/EPC/>

Authorized Service Shops Location

09/16

- The purchaser must contact a Lincoln Authorized Service Facility (LASF) about any defect claimed under Lincoln's warranty period.
- Contact your local Lincoln Sales Representative for assistance in locating a LASF or go to www.lincolnelectric.com/en-gb/Support/Locator.

Electrical Schematic

Refer to the "Electrical Schematics" section.